

ACAT

TEL 81 8354 8910
www.acatmexicans.com

T3 Series

HIGH FORCE GAS SPRINGS

*IDEAL FOR LIMITED
HEIGHT APPLICATIONS
REQUIRING HIGH FORCE*



HYSON
Metal Forming Solutions™

Since 1964 HYSON Metal Forming Solutions has been dedicated to providing safer and more reliable products with worldwide support and service. We are continually at the forefront of innovative product design and engineer forward-thinking features into our self-contained springs that enable our customers to provide safer working environments.

Our nitrogen gas springs, which comply with all major industry standards are designed to reduce risk of tool damage and injuries due to parts separating under high pressure and include at least one vital safety features:



Overstroke Protection:

In the event of an overstroke, the HYSON cylinder is designed to fail-safe and release pressure in a pre-defined manner with deformation or knockout plug.



Overpressure Protection:

Designed to vent excessive gas in the event that the spring becomes overpressured with drawing fluid, deformation of the safety lip guide or separation of disc will occur.



Overload Protection:

Reduce injuries and press damage with Overload Protection - In case of jammed tool, part or rod side-load, the piston rod is designed for controlled gas venting between the seal and piston rod with a specially designed guide and fundamental safety stop.



PED - Pressure Equipment Directive

The majority of HYSON nitrogen gas springs are PED (Pressure Equipment Directive) approved to withstand a minimum of 2 million full cycles according to PED 2014/68/EU. Many of our competitors are in compliance of PED, but compliance is unequal to the 2 million cycle test and approval that HYSON gas springs have undergone. This is one more assurance that with HYSON Nitrogen Gas Springs you receive an added value of safety reliability and operational excellence. The Pressure Equipment Directive (PED) replaces all previous European legislation governing the design, manufacture and testing of pressure vessels.



Genuinely HYSON Safety App

Created to enable safer working environments and fight against unsafe counterfeit springs in manufacturing facilities around the globe, the Genuinely HYSON Safety App authenticates the nitrogen gas springs with Hyson labeling have the design and safety features customers have come to expect with the Hyson brand.

The App is available for download at www.HysonSolutions.com.

THE HIGHEST FORCE IN SMALL SPACE

Table of Contents

GENUINELY HYSON	
General Information	2
Product Value.....	2
T3 Series Features	2
ISO 9001:2008 certification.....	2
Mounting Guidelines.....	2
Product Specifications	3
Ordering Instructions.....	3
Mounting Options.....	3
Repair Kits.....	3
Gas spring models	
T3-170.....	4
T3-320.....	6
T3-350.....	8
T3-500	10
T3-750.....	12
T3-1000.....	14
T3-1500.....	16
T3-2400.....	18
T3-4200	20
T3-6600	22
T3-9500	24
T3-20000	26



General Information

HYSON Metal Forming Solutions, headquartered in Brecksville Ohio, is a world class engineered product and manufacturing company providing high-quality, safety-engineered force control to a wide range of industries and applications. Throughout the years, the company has remained at the forefront of technical innovation, developing forming solutions for critical machine, vehicle and precision metal processing applications. Our success lies with our commitment to continually improve ourselves, our processes and our products to ensure we meet or exceed our customer's expectations. Our AS-9100, ISO 9001:2008 certification and PED certifications attest to our ongoing commitment to the highest standards of quality.

Product Value

- The highest force nitrogen gas spring in the smallest space.
- The T3 models comply with the standards, ISO 11901-3 and VDI 3003 Part 3.
- Reduces your cost per ton

T3 Series Features

- Twelve models with contact forces from 380 lbf to 45,000 lbf.
- Extended stroke lengths to 125 mm/4.92 in.
- Variety of mounting options available.
- Standard charge ports work with most charging equipment.

ISO 9001:2008 certification

Focused on meeting customer expectations, ISO 9001 is an internationally recognized standard for quality management with certificates issued to organization in 178 countries. This highly regarded certification reflects HYSON's ongoing commitment to deliver solutions that meet the highest quality standards.



Mounting Guidelines

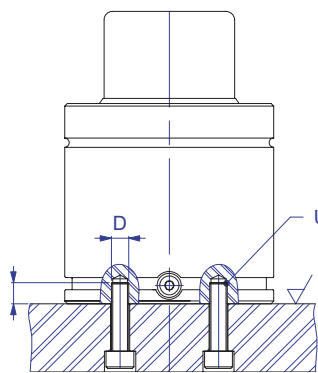

For example: T3 2400

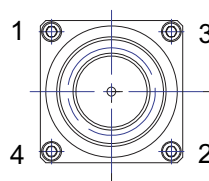

When tightening the mounting screws in the tool, apply an evenly cross like pattern according to the picture (1-2-3-4). Otherwise there is a risk for the mount to tilt.

For those gas springs whose thread depth (E) is less than 1 times its thread size (D) we recommend the following:

- select a screw length to engage all available thread depth
- use a thread locking compound
- ensure the correct screw torque setting is applied

Thread	Torque (for screw class 8.8 according to ISO 898-1)
M6	10 Nm
M8	24 Nm
M10	45 Nm
M12	80 Nm
M16	160-200 Nm

Product Specifications

Pressure Medium:	Nitrogen
Max. Charging Pressure:	
T3-170, T3-320, T3-350	180 bar/2610 psi
T3-500, T3-750, T3-1000, T3-1500, T3-2400, T3-4200, T3-6600, T3-9500, T3-20000	150 bar/2175 psi
Min. Charging Pressure:	25 bar/365 psi
Operating Temperature:	0 ° to 80 °C/32 ° to 176 °F
Force Increase by Temperature:	+0.3% per °C/+0.009% per °F
Recommended Max. Strokes/Min:	~15-100 @20 °C/68 °F
Max. Piston Rod Velocity:	1.6 m/s / 315 ft per min
Max. Utilized Stroke:	100%
Valve Inlet:	
T3-170, T3-320, T3-500, T3-750, T3-1000, T3-1500, T3-2400, T3-4200.....	4018112
T3-6600, T3-9500, T3-20000	56-072-5500
Charge Fitting:	
T3-170, T3-320, T3-350, T3-500, T3-750, T3-1000, T3-1500, T3-2400.....	T2-770-T3
T3-4200, T3-6600, T3-9500, T3-20000.....	T2-770-G1/8-P

Ordering Instructions

T3-1500	X	50
Model		Stroke (mm)
T3-170		See Dimensional Information Charts
T3-320		
T3-350		
T3-500		
T3-750		
T3-1000		
T3-1500		
T3-2400		
T3-4200		
T3-6600		
T3-9500		
T3-20000		

Repair Kits

Gas Spring	Repair Kit Order Number
T3-350	T3SK-350
T3-500	T3SK-500
T3-750	T3SK-750
T3-1000	T3SK-1000
T3-1500	T3SK-1500
T3-2400	T3SK-2400
T3-4200	T3SK-4200
T3-6600	T3SK-6600
T3-9500	T3SK-9500
T3-20000	T3SK-20000

Note: The T3-2400x16 and T3-2400x19 are not possible to repair.

Mounting Options

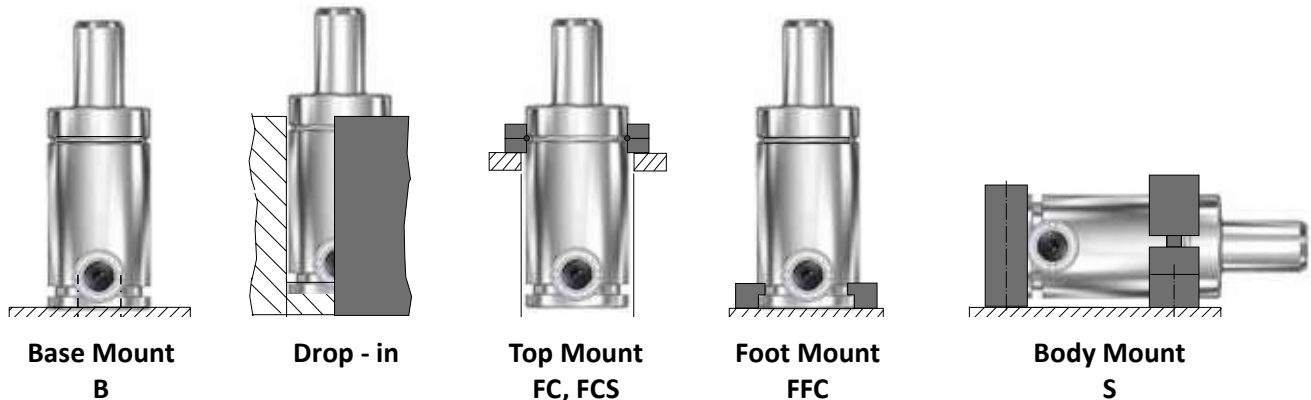

T3-170

High Force Gas Springs

Advanced Safety Feature



V > max
Overload Protection



P > max
Overpressure Protection

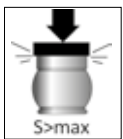

S > max
Overstroke Protection

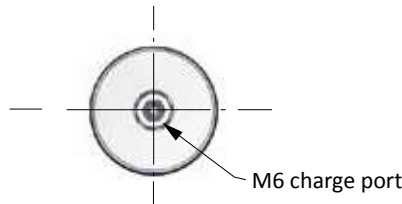
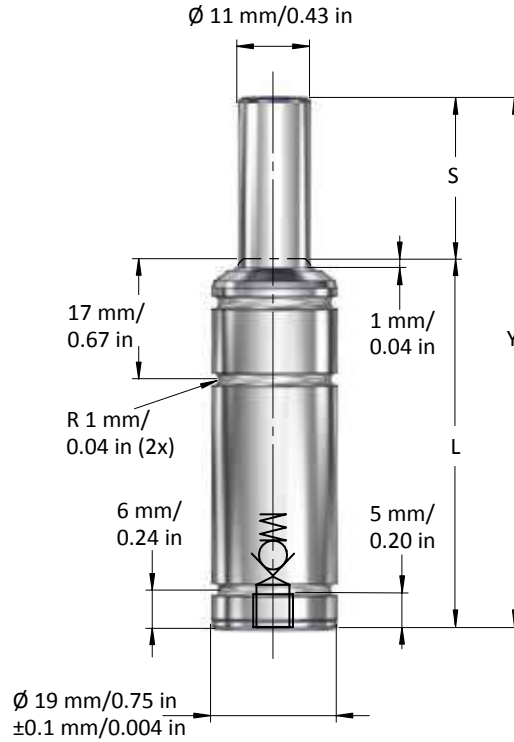

T3-170 Dimensional Information

Order Number Model x Stroke	Stroke S		Contact Force 2610 psi at 68° F		Full Stroke Force		Cylinder Height		Body Height		Gas volume	Weight
	mm	in	N	lbf.	N	lbf.	Y ±0.25	Y ±0.010	L	L		
							mm	in	mm	in	ℓ	kg
Preferred Stroke Lengths (optimal delivery)												
T3-170x25	25	0.98	1,700	380	2,800	630	80	3.15	55	2.17	0.006	0.08
T3-170x38	38	1.50					106	4.17	68	2.68	0.009	0.09
T3-170x50	50	1.97					130	5.12	80	3.15	0.012	0.10
T3-170x63	63	2.48					156	6.14	93	3.66	0.015	0.12
Alternative Stroke Lengths												
T3-170x7	7	0.28	1,700	380	2,800	630	44	1.73	37	1.46	0.002	0.06
T3-170x10	10	0.39					50	1.97	40	1.57	0.002	0.06
T3-170x15	15	0.59					60	2.36	45	1.77	0.004	0.07
T3-170x19	19	0.75					68	2.68	49	1.93	0.005	0.07
T3-170x75	75	2.95					185	7.28	110	4.33	0.018	0.14
T3-170x80	80	3.15					195	7.68	115	4.53	0.019	0.14
T3-170x100	100	3.94					235	9.25	135	5.31	0.024	0.16
T3-170x125	125	4.92					285	11.22	160	6.30	0.030	0.19

Note: All dimensions are nominal. Data shown are typical. Actual data for any particular unit may vary.

Note: All flanges ordered separately

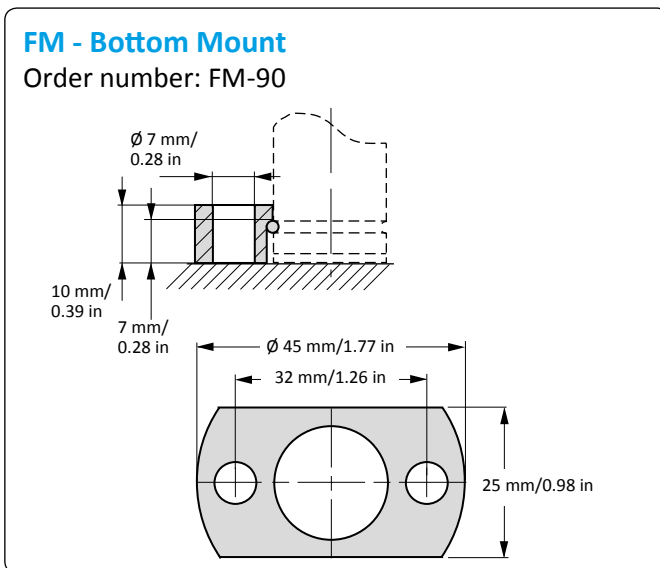
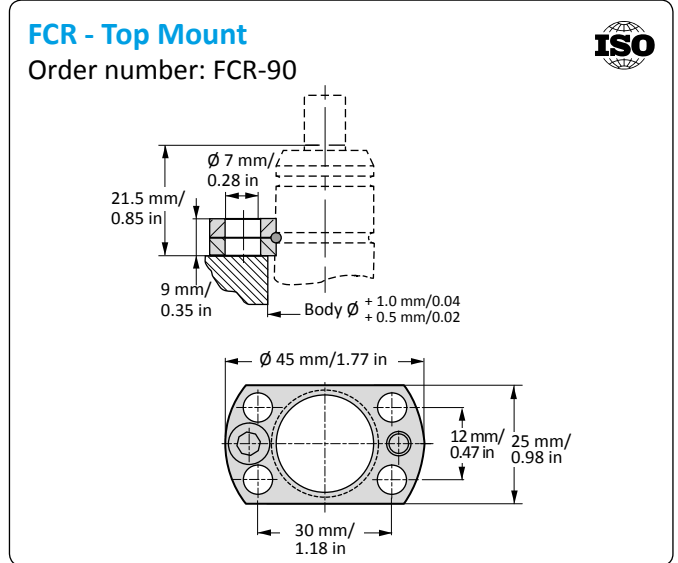
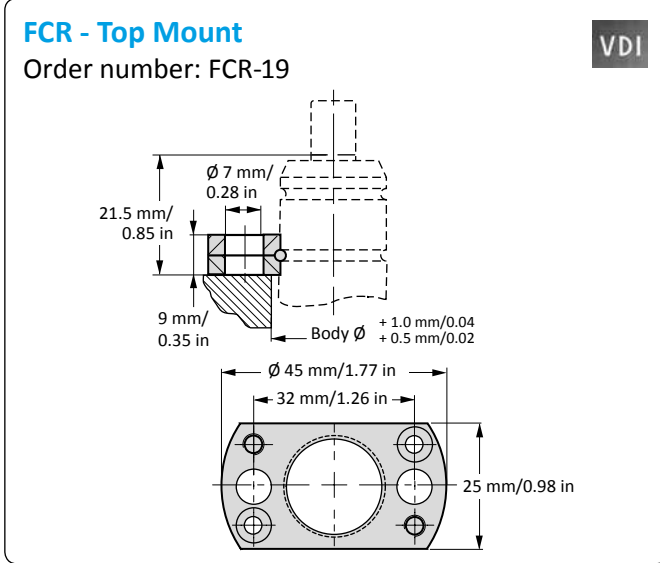

Bottom mount to be used for strokes from $7\text{-}25 \text{ mm} / 0.28\text{-}0.98 \text{ in}$ only

T3-320

High Force Gas Springs

Advanced Safety Features



V>max
Overload Protection



P>max
Overpressure Protection

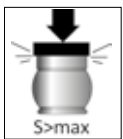

S>max
Overstroke Protection

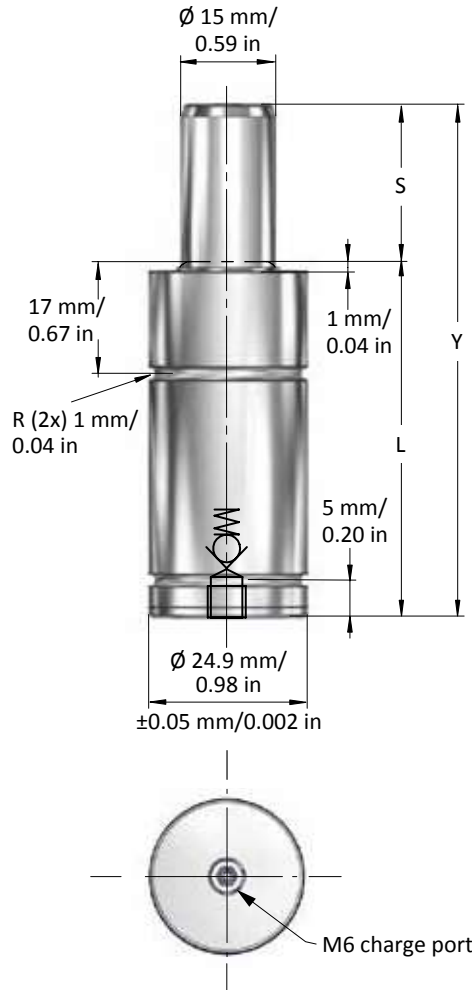

T3-320 Dimensional Information

Order Number Model x Stroke	Stroke S		Contact Force 2610 psi at 68° F		Full Stroke Force		Cylinder Height		Body Height		Gas volume	Weight
	mm	in	N	lbf.	N	lbf.	Y ±0.25		Y ±0.010			
							mm	in	mm	in	mm	in
Preferred Stroke Lengths (optimal delivery)												
T3-320x25	25	0.98	3,200	720	5,200	1,170	80	3.15	55	2.17	0.011	0.14
T3-320x38	38	1.50			5,300	1,190	106	4.17	68	2.68	0.017	0.16
T3-320x50	50	1.97			5,300	1,190	130	5.12	80	3.15	0.022	0.19
T3-320x63	63	2.48			5,300	1,190	156	6.14	93	3.66	0.028	0.21
Alternative Stroke Lengths												
T3-320x7	7	0.28	3,200	720	4,800	1,080	44	1.73	37	1.46	0.004	0.10
T3-320x10	10	0.39			4,900	1,100	50	1.97	40	1.57	0.005	0.11
T3-320x15	15	0.59			5,100	1,150	60	2.36	45	1.77	0.007	0.12
T3-320x19	19	0.75			5,100	1,150	68	2.68	49	1.93	0.009	0.13
T3-320x75	75	2.95			5,300	1,190	185	7.28	110	4.33	0.034	0.24
T3-320x80	80	3.15			5,300	1,190	195	7.68	115	4.53	0.036	0.25
T3-320x100	100	3.94			5,300	1,190	235	9.25	135	5.31	0.044	0.29
T3-320x125	125	4.92			5,300	1,190	285	11.22	160	6.30	0.055	0.33

Note: All dimensions are nominal. Data shown are typical. Actual data for any particular unit may vary.

Note: All flanges ordered separately

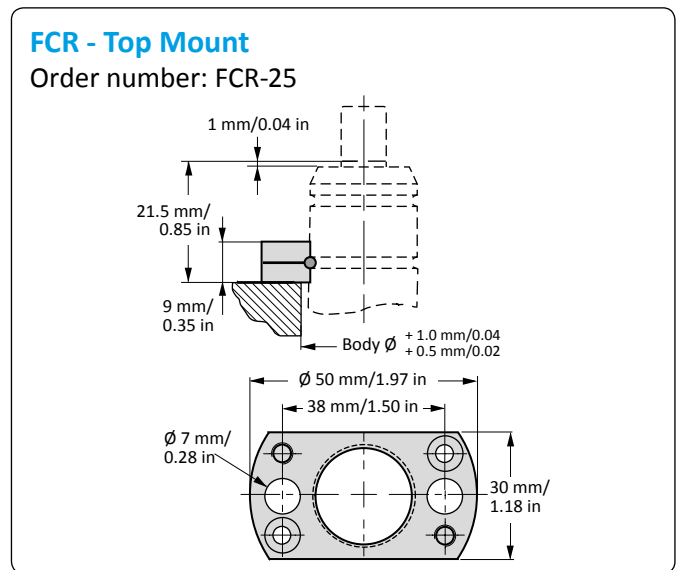
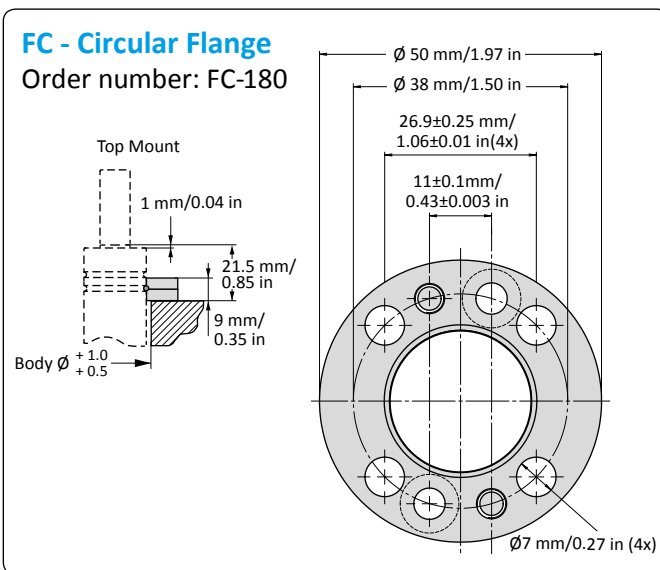
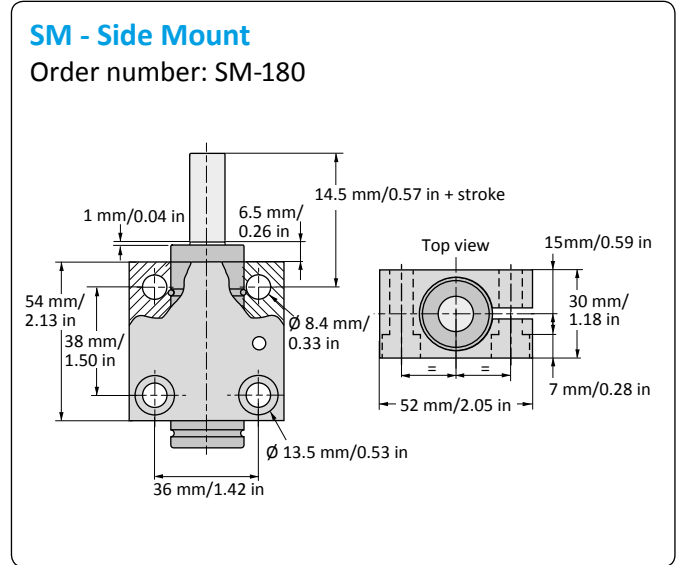
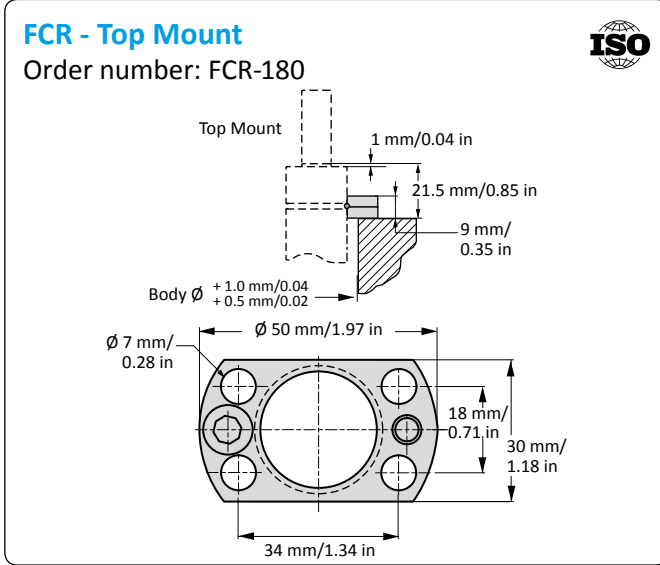

T3-350

High Force Gas Springs

Advanced Safety Features



Overload Protection



Overpressure Protection

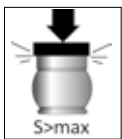

Overstroke Protection

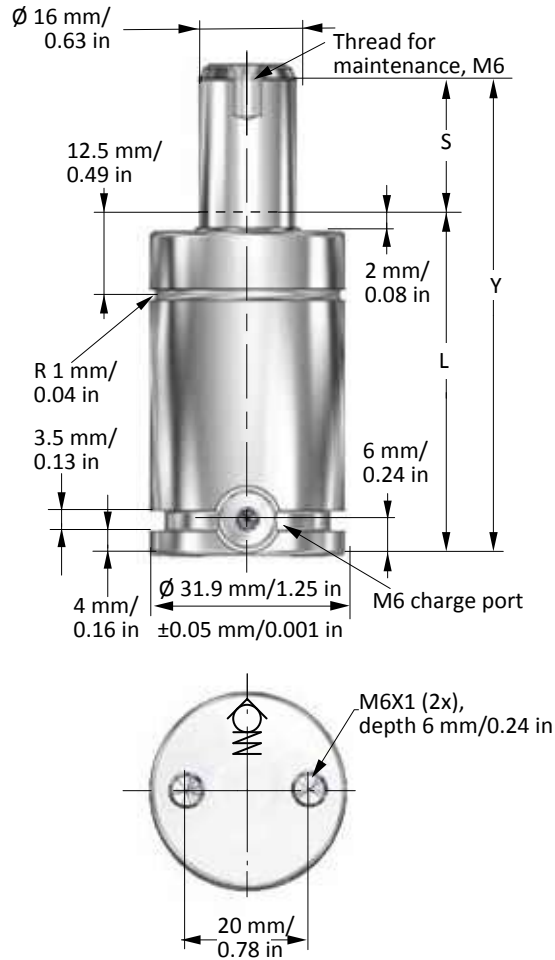

T3-350 Dimensional Information

Order Number Model x Stroke	Stroke S		Contact Force 2610 psi at 68° F		Full Stroke Force		Cylinder Height		Body Height		Gas volume	Weight
	mm	in	N	lbf.	N	lbf.	Y ±0.25 mm	Y ±0.010 in	L mm	L in		
Preferred Stroke Lengths (optimal delivery)												
T3-350x25	25	0.98	3,600	810	5,500	1,235	80	3.15	55	2.17	0.02	0.22
T3-350x38	38	1.50			5,500	1,240	106	4.17	68	2.68	0.03	0.26
T3-350x50	50	1.97			5,500	1,260	130	5.12	80	3.15	0.03	0.29
T3-350x63	63	2.48			5,500	1,260	156	6.14	93	3.66	0.04	0.33
Alternative Stroke Lengths												
T3-350x10	10	0.39	3,600	810	5,900	1,330	50	1.97	40	1.57	0.01	0.17
T3-350x13	13	0.51			5,200	1,190	56	2.20	43	1.69	0.01	0.18
T3-350x16	16	0.63			5,300	1,210	62	2.44	46	1.81	0.01	0.19
T3-350x19	19	0.75			5,600	1,260	68	2.68	49	1.93	0.01	0.20
T3-350x32	32	1.26			5,500	1,235	94	3.70	62	2.44	0.02	0.24
T3-350x75	75	2.95			5,500	1,260	180	7.09	105	4.13	0.05	0.37
T3-350x80	80	3.15			5,500	1,240	190	7.48	110	4.33	0.05	0.39
T3-350x100	100	3.94			5,500	1,240	230	9.06	130	5.12	0.06	0.45
T3-350x125	125	4.92			5,500	1,240	280	11.02	155	6.10	0.08	0.53

Note: All dimensions are nominal. Data shown are typical. Actual data for any particular unit may vary.

Note: All flanges ordered separately

FC - Circular Flange

Order number: FC-350

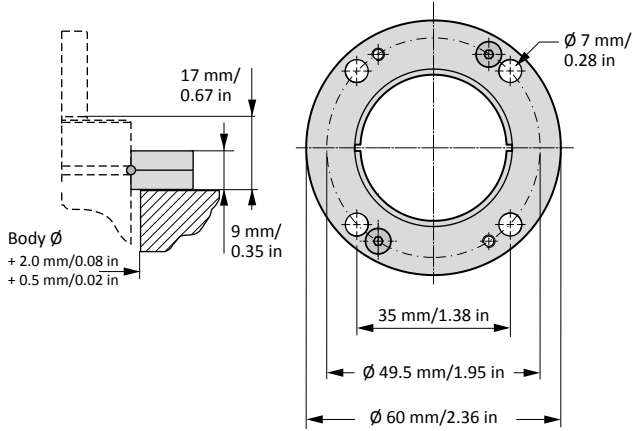

FFC - Lower Square Flange

Order number: FFC-350

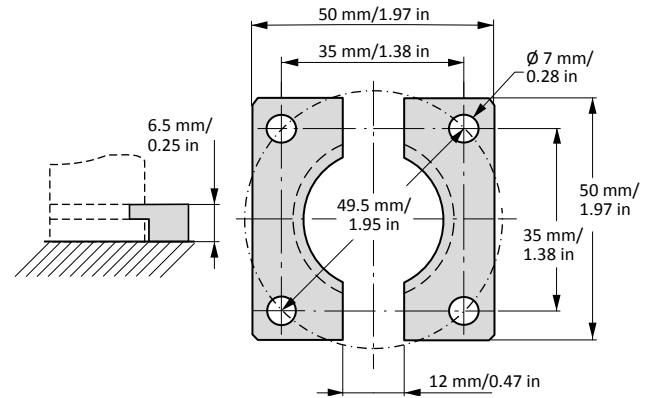

FCS - Upper Square Flange

Order number: FCS-32

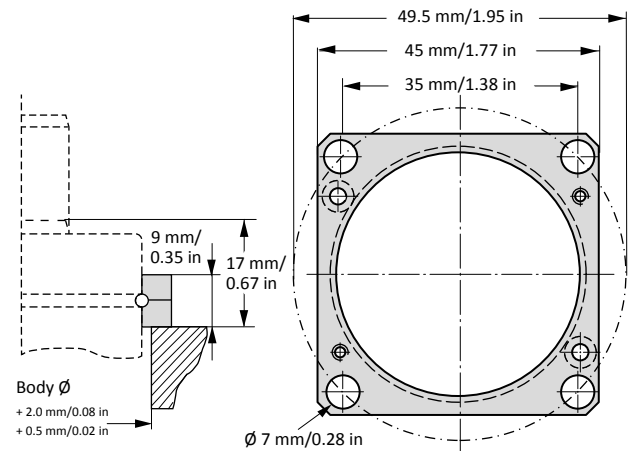

T3-500

High Force Gas Springs



Advanced Safety Features



Overload Protection



Overpressure Protection

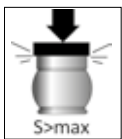

Overstroke Protection

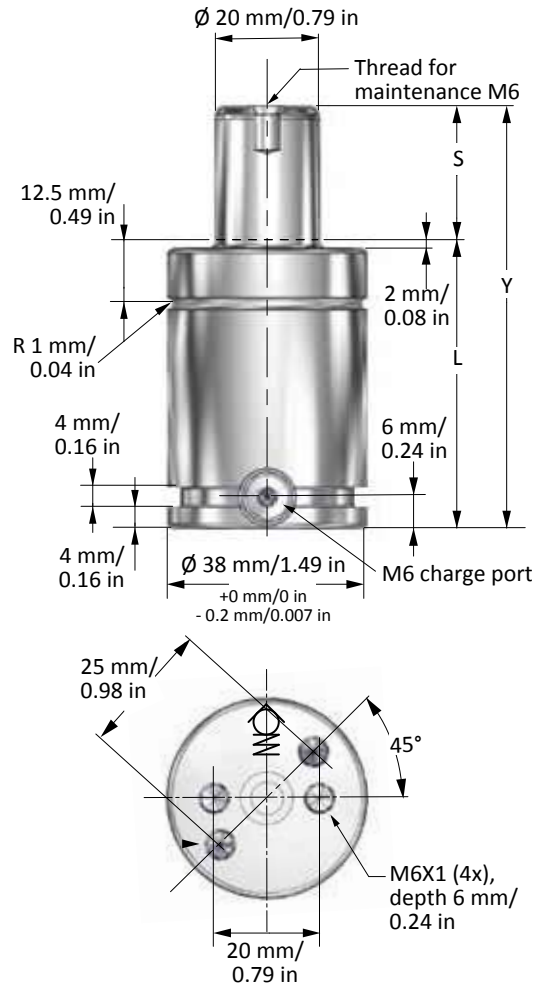

T3-500 Dimensional Information

Order Number Model x Stroke	Stroke S		Contact Force 2175 psi at 68° F		Full Stroke Force		Cylinder Height		Body Height		Gas volume ℓ	Weight kg
	mm	in	N	lbf.	N	lbf.	Y ±0.25 mm	Y ±0.010 in	L mm	L in		
Preferred Stroke Lengths (optimal delivery)												
T3-500x25	25	0.98	4,700	1,055	7,300	1,640	80	3.15	55	2.17	0.03	0.31
T3-500x38	38	1.50			7,200	1,620	106	4.17	68	2.68	0.04	0.36
T3-500x50	50	1.97			7,200	1,620	130	5.12	80	3.15	0.05	0.41
T3-500x63	63	2.48			7,200	1,620	156	6.14	93	3.66	0.06	0.46
Alternative Stroke Lengths												
T3-500x10	10	0.39	4,700	1,055	7,200	1,620	50	1.97	40	1.57	0.01	0.25
T3-500x13	13	0.51			7,100	1,600	56	2.20	43	1.69	0.01	0.26
T3-500x16	16	0.63			7,200	1,620	62	2.44	46	1.81	0.02	0.27
T3-500x19	19	0.75			7,400	1,660	68	2.68	49	1.93	0.02	0.29
T3-500x32	32	1.26			7,200	1,620	94	3.7	62	2.44	0.03	0.34
T3-500x75	75	2.95			7,100	1,600	180	7.08	105	4.13	0.07	0.50
T3-500x80	80	3.15			7,100	1,600	190	7.48	110	4.33	0.08	0.52
T3-500x100	100	3.94			7,100	1,600	230	9.06	130	5.12	0.10	0.60
T3-500x125	125	4.92			7,100	1,600	280	11.02	155	6.10	0.12	0.69

Note: All dimensions are nominal. Data shown are typical. Actual data for any particular unit may vary.

Note: All flanges ordered separately

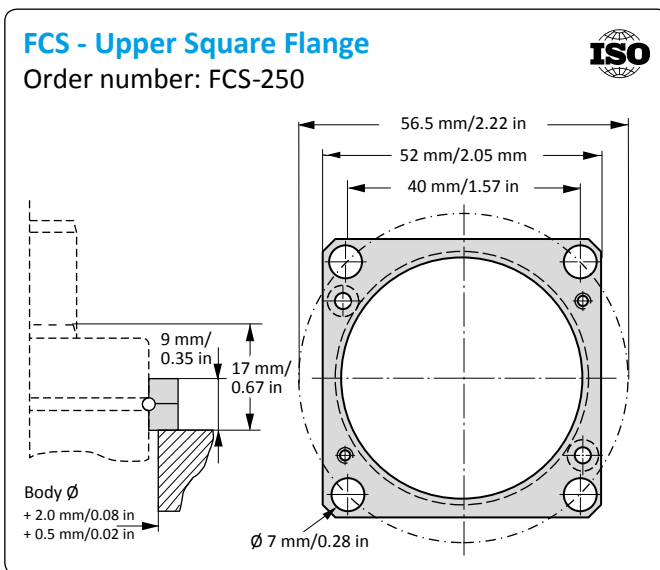
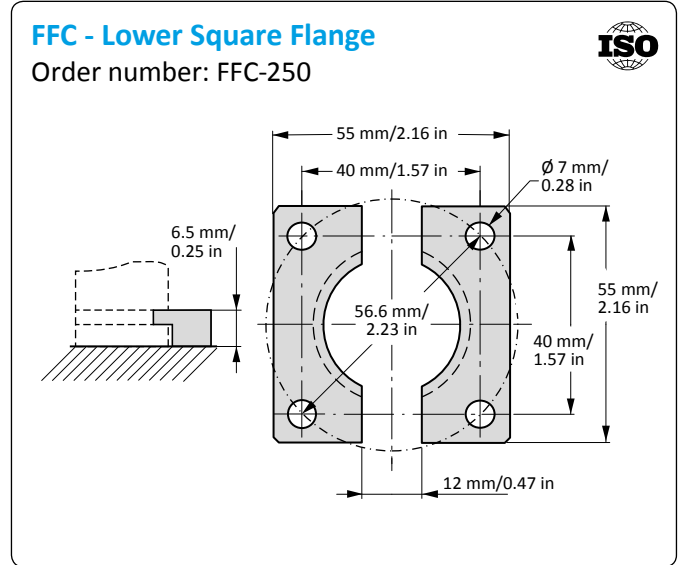
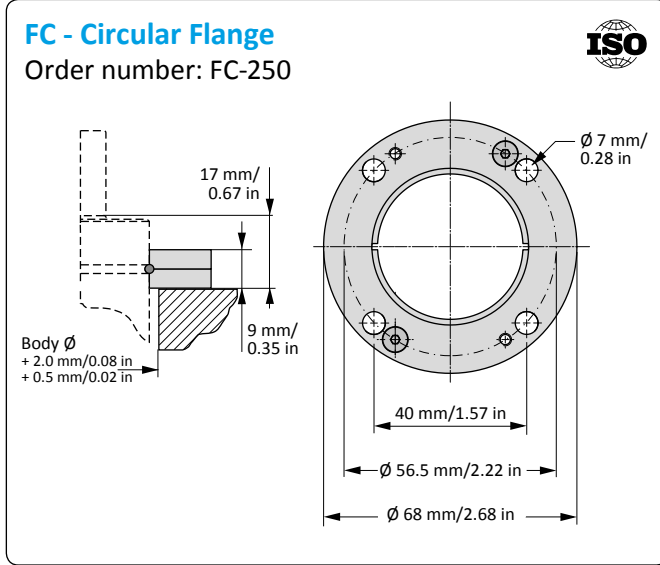

T3-750

High Force Gas Springs

Advanced Safety Features



V>max
Overload Protection



P>max
Overpressure Protection

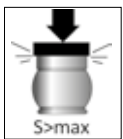

S>max
Overstroke Protection

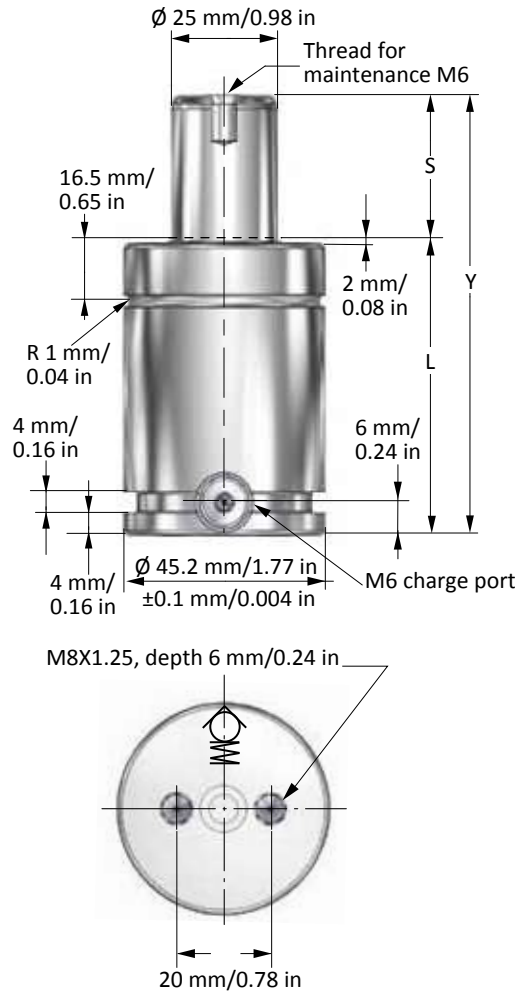

T3-750 Dimensional Information

Order Number Model x Stroke	Stroke S		Contact Force 2175 psi at 68° F		Full Stroke Force		Cylinder Height		Body Height		Gas volume	Weight
	mm	in	N	lbf.	N	lbf.	Y ± 0.25	Y ± 0.010	L	L		
Preferred Stroke Lengths (optimal delivery)												
T3-750x25	25	0.98	7,400	1,665	11,800	2,650	82	3.23	57	2.24	0.04	0.45
T3-750x38	38	1.50			11,800	2,650	108	4.25	70	2.76	0.05	0.53
T3-750x50	50	1.97			11,800	2,650	132	5.20	82	3.23	0.07	0.61
T3-750x63	63	2.48			11,800	2,650	158	6.22	95	3.74	0.09	0.69
Alternative Stroke Lengths												
T3-750x10	10	0.39	7,400	1,665	12,100	2,720	52	2.05	42	1.65	0.02	0.37
T3-750x13	13	0.51			12,100	2,720	58	2.28	45	1.77	0.02	0.39
T3-750x16	16	0.63			12,100	2,720	64	2.52	48	1.89	0.03	0.41
T3-750x19	19	0.75			11,700	2,630	70	2.76	51	2.01	0.03	0.41
T3-750x32	32	1.26			11,800	2,650	96	3.78	64	2.52	0.05	0.50
T3-750x75	75	2.95			11,900	2,675	182	7.17	107	4.21	0.10	0.77
T3-750x80	80	3.15			11,900	2,675	192	7.56	112	4.41	0.11	0.80
T3-750x100	100	3.94			11,900	2,675	232	9.13	132	5.20	0.13	0.93
T3-750x125	125	4.92			11,900	2,675	282	11.10	157	6.18	0.17	1.09

Note: All dimensions are nominal. Data shown are typical. Actual data for any particular unit may vary.

Note: All flanges ordered separately

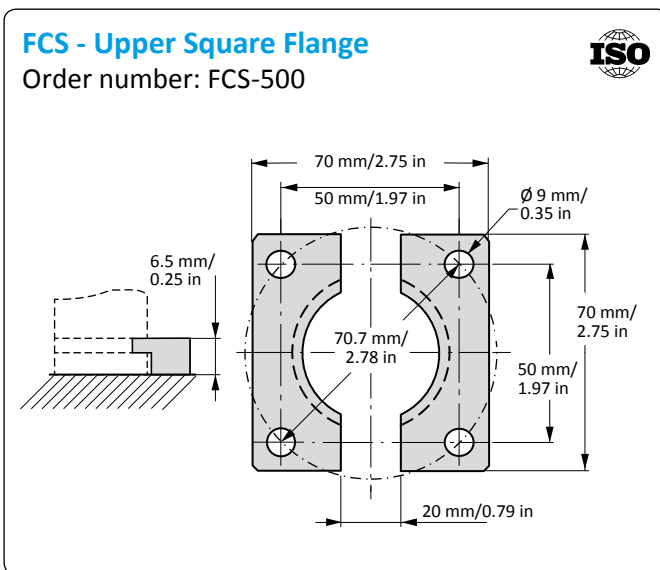
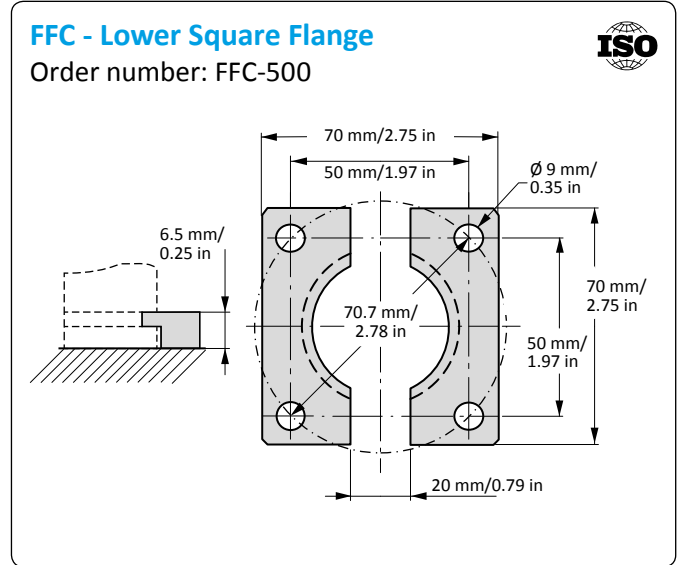
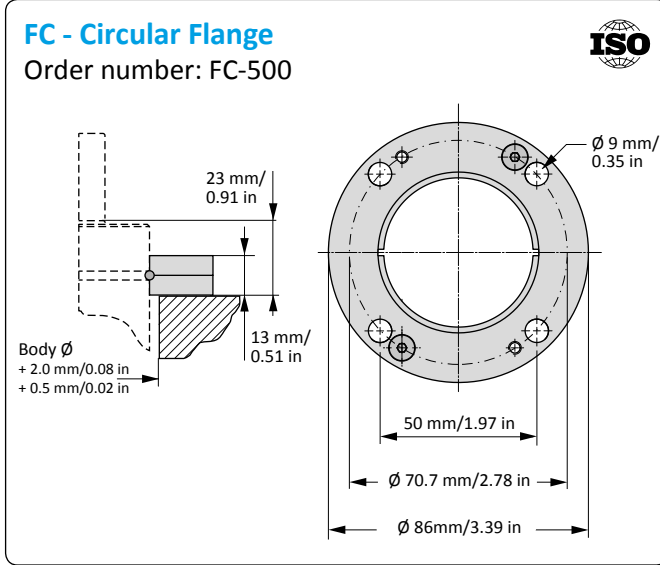

T3-1000

High Force Gas Springs



Advanced Safety Features



V>max
Overload
Protection



P>max
Overpressure
Protection

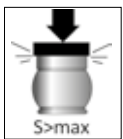

S>max
Overstroke
Protection

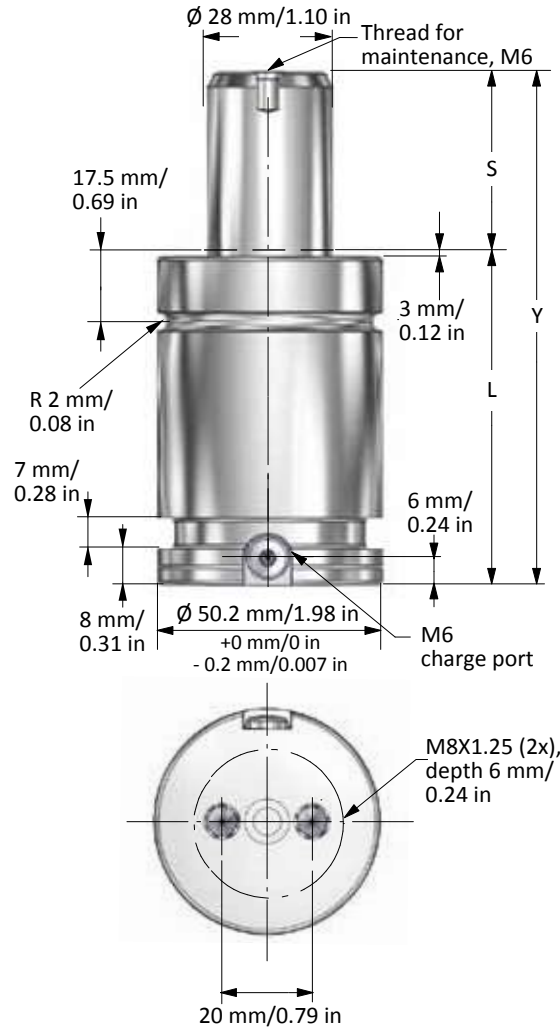

T3-1000 Dimensional Information

Order Number Model x Stroke	Stroke S		Contact Force 2175 psi at 68° F		Full Stroke Force		Cylinder Height		Body Height		Gas volume ℓ	Weight kg
	mm	in	N	lbf.	N	lbf.	Y ±0.25		L			
							mm	in	mm	in		
Preferred Stroke Lengths (optimal delivery)												
T3-1000x25	25	0.98	9,200	2,070	14,200	3,190	88	3.46	63	2.48	0.05	0.59
T3-1000x38	38	1.50			14,500	3,260	114	4.49	76	2.99	0.07	0.70
T3-1000x50	50	1.97			14,600	3,280	138	5.43	88	3.46	0.09	0.79
T3-1000x63	63	2.48			14,700	3,305	164	6.46	101	3.96	0.11	0.89
Alternative Stroke Lengths												
T3-1000x13	13	0.51	9,200	2,070	13,800	3,105	64	2.53	51	2.01	0.03	0.50
T3-1000x16	16	0.63			13,800	3,105	70	2.76	54	2.13	0.04	0.52
T3-1000x19	19	0.75			14,000	3,145	76	2.99	57	2.24	0.04	0.54
T3-1000x32	32	1.26			14,300	3,215	102	4.02	70	2.76	0.06	0.64
T3-1000x75	75	2.95			14,700	3,305	188	7.40	113	4.45	0.13	0.99
T3-1000x80	80	3.15			14,800	3,325	198	7.80	118	4.65	0.14	1.03
T3-1000x100	100	3.94			14,800	3,325	238	9.37	138	5.43	0.17	1.19
T3-1000x125	125	4.92			14,800	3,325	288	11.34	163	6.41	0.21	1.39

Note: All dimensions are nominal. Data shown are typical. Actual data for any particular unit may vary.

Note: All flanges ordered separately

FC - Circular Flange

Order number: FC-750

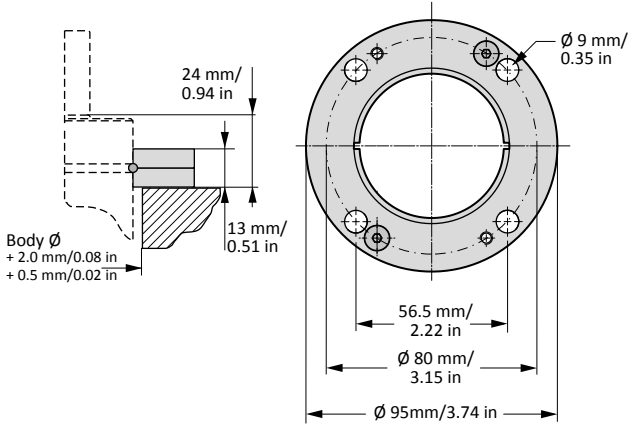

FCS - Upper Square Flange

Order number: FCS-750

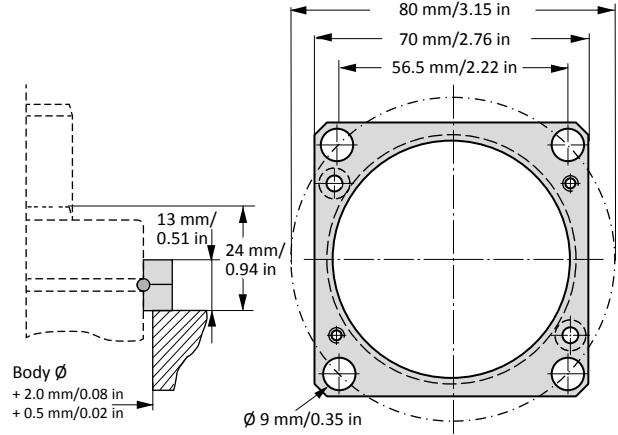

S-Support Mount

Order number: S-750



Note! Support S is designed to be used in combination with flanges mounted in the U or C groove or base mounting option. The mounting screw (M8) should be tightened with torque 25 Nm.

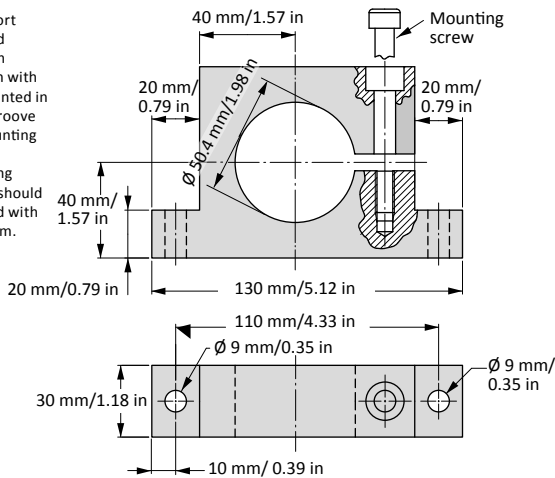

FFC - Lower Square Flange

Order number: FFC-750

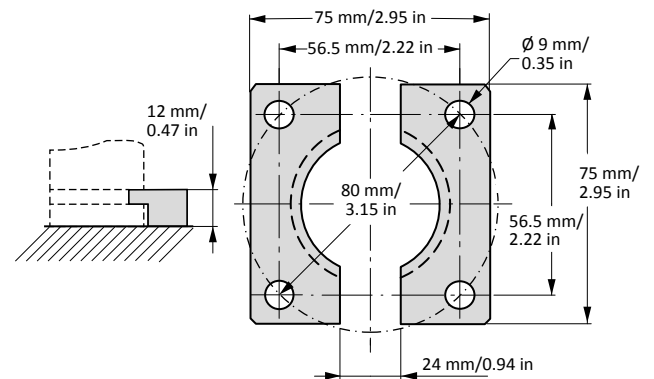

MP - Base Mounting Flange

Order number: MP-750

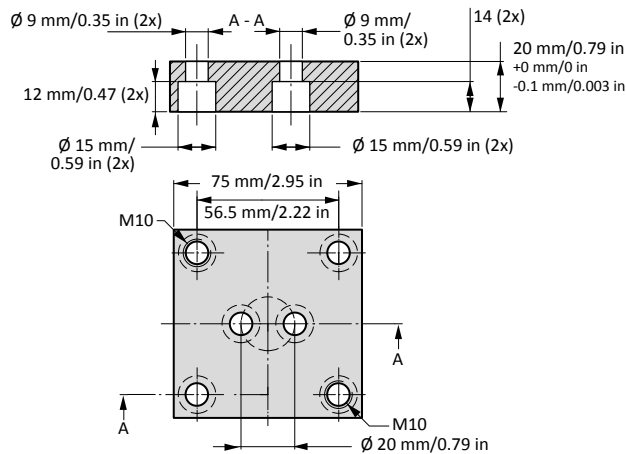

T3-1500

High Force Gas Springs



Advanced Safety Features



V>max
Overload Protection



P>max
Overpressure Protection

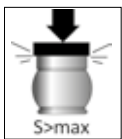

S>max
Overstroke Protection

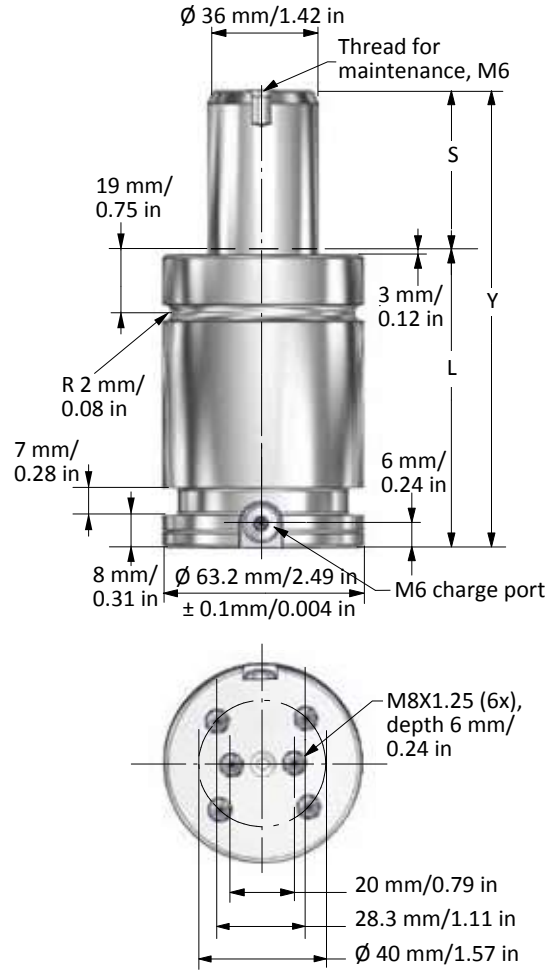

T3-1500 Dimensional Information

Order Number Model x Stroke	Stroke S		Contact Force 2175 psi at 68° F		Full Stroke Force		Cylinder Height		Body Height		Gas volume ℓ	Weight kg
	mm	in	N	lbf.	N	lbf.	Y ±0.25		Y ±0.010			
							mm	in	mm	in		
Preferred Stroke Lengths (optimal delivery)												
T3-1500x25	25	0.98	15,000	3,375	24,300	5,365	94	3.70	69	2.72	0.08	1.03
T3-1500x38	38	1.50			23,900	5,375	120	4.72	82	3.23	0.12	1.15
T3-1500x50	50	1.97			24,000	5,395	144	5.67	94	3.70	0.15	1.28
T3-1500x63	63	2.48			24,100	5,420	170	6.69	107	4.21	0.19	1.43
Alternative Stroke Lengths												
T3-1500x13	13	0.51	15,000	3,375	24,000	5,395	70	2.76	57	2.24	0.05	0.89
T3-1500x16	16	0.63			24,100	5,420	76	2.99	60	2.36	0.06	0.93
T3-1500x19	19	0.75			24,200	5,440	82	3.23	63	2.48	0.07	0.96
T3-1500x32	32	1.26			23,800	5,355	108	4.25	76	2.99	0.11	1.08
T3-1500x75	75	2.95			24,200	5,440	194	7.64	119	4.69	0.22	1.57
T3-1500x80	80	3.15			24,200	5,440	204	8.03	124	4.88	0.24	1.63
T3-1500x100	100	3.94			24,300	5,465	244	9.61	144	5.67	0.29	1.86
T3-1500x125	125	4.92			24,300	5,465	294	11.57	169	6.65	0.36	2.15

Note: All dimensions are nominal. Data shown are typical. Actual data for any particular unit may vary.

Note: All flanges ordered separately

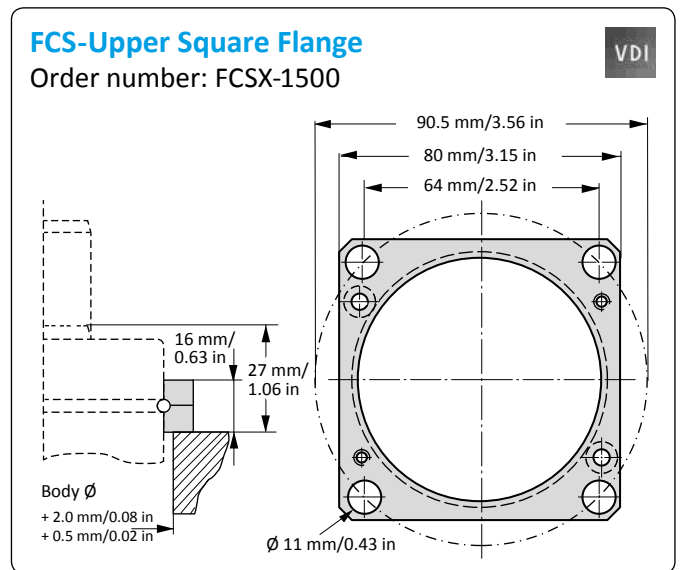
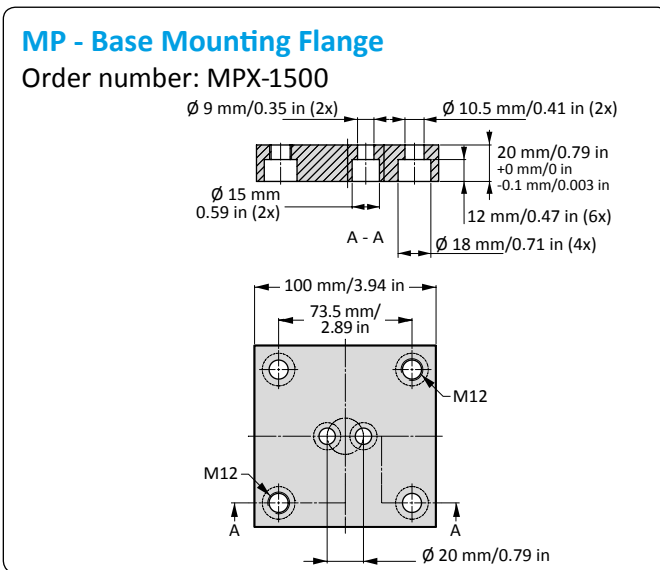
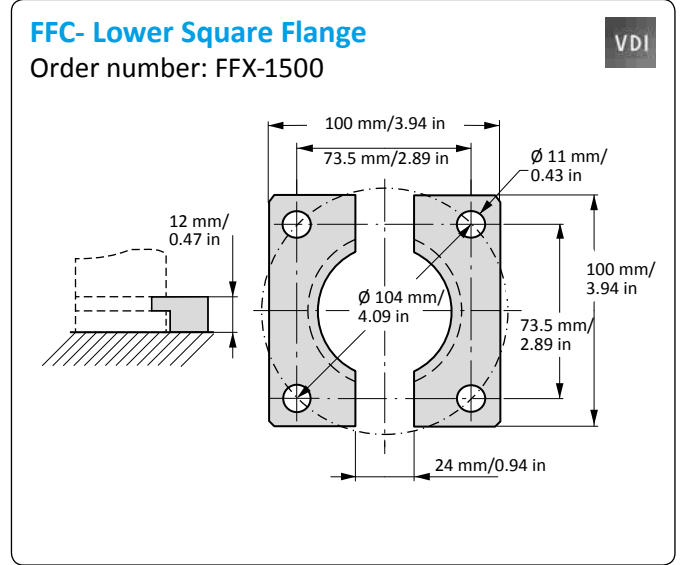
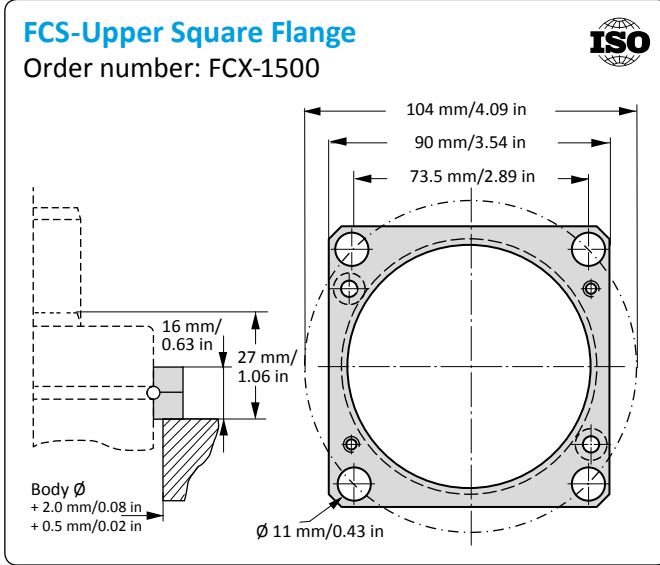

T3-2400

High Force Gas Springs

Advanced Safety Features



Overload Protection



Overpressure Protection

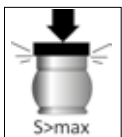

Overstroke Protection

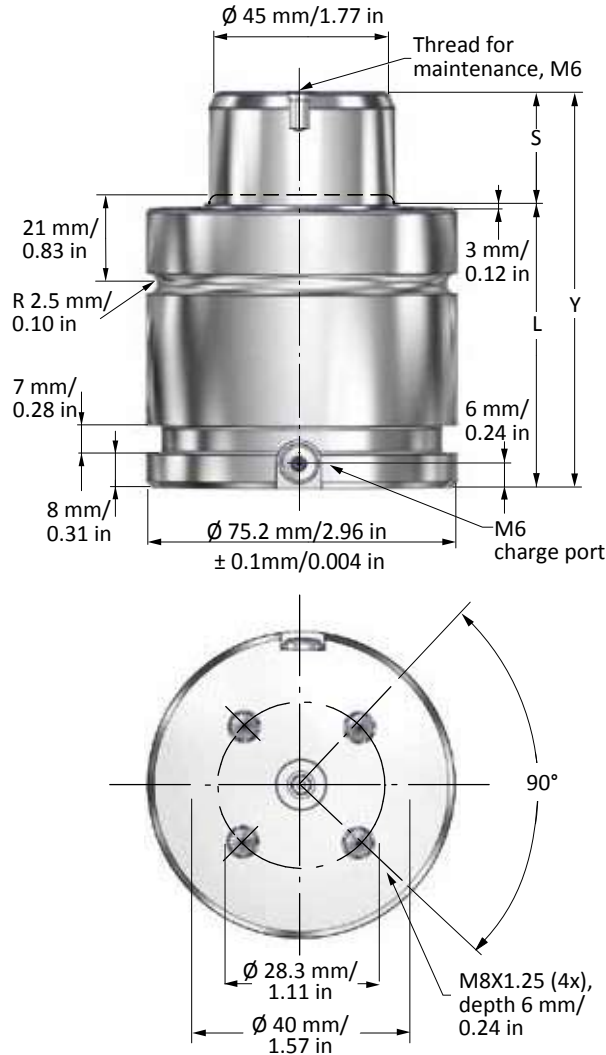

T3-2400 Dimensional Information

Order Number Model x Stroke	Stroke S		Contact Force 2175 psi at 68° F		Full Stroke Force		Cylinder Height		Body Height		Gas volume ℓ	Weight kg
	mm	in	N	lbf.	N	lbf.	Y ±0.25 mm	Y ±0.010 in	L mm	L in		
Preferred Stroke Lengths (optimal delivery)												
T3-2400x25	25	0.98	24,000	5,395	38,700	8,700	95	3.74	70	2.76	0.13	1.45
T3-2400x38	38	1.50			38,400	8,635	121	4.76	83	3.27	0.18	1.65
T3-2400x50	50	1.97			39,200	8,815	145	5.71	95	3.74	0.23	1.84
T3-2400x63	63	2.48			39,200	8,815	171	6.73	108	4.25	0.28	2.20
Alternative Stroke Lengths												
T3-2400x16	16	0.63	24,000	5,395	38,300	8,610	77	3.03	61	2.40	0.09	1.34
T3-2400x19	19	0.75			38,500	8,655	83	3.27	64	2.52	0.10	1.38
T3-2400x32	32	1.26			38,600	8,680	109	4.29	77	3.03	0.16	1.56
T3-2400x75	75	2.95			39,200	8,815	195	7.68	120	4.72	0.33	2.26
T3-2400x80	80	3.15			39,200	8,815	205	8.07	125	4.92	0.35	2.32
T3-2400x100	100	3.94			39,300	8,835	245	9.65	145	5.71	0.43	2.66
T3-2400x125	125	4.92			39,300	8,835	295	11.61	170	6.69	0.54	3.05

Note: All dimensions are nominal. Data shown are typical. Actual data for any particular unit may vary.

Note: All flanges ordered separately

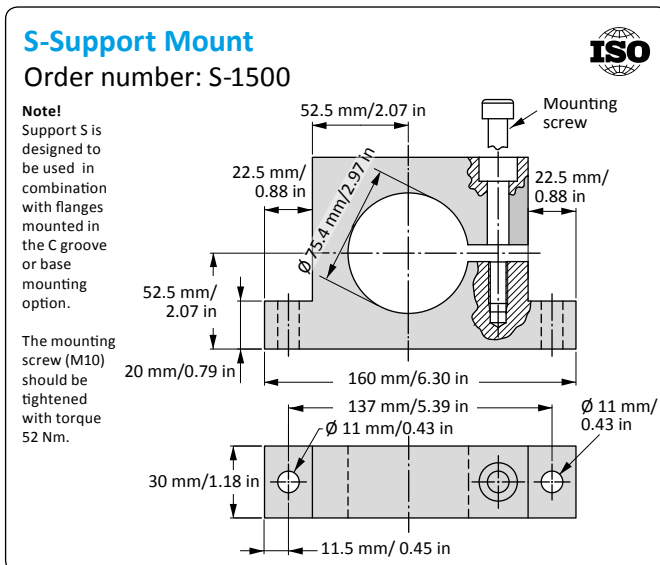
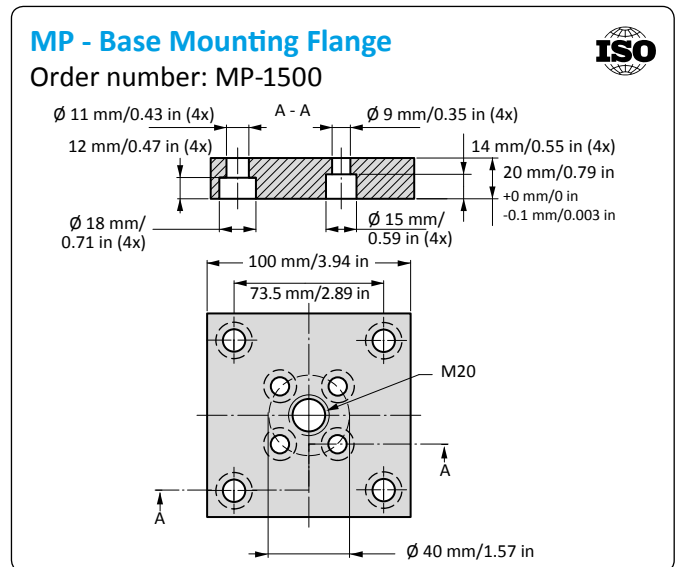
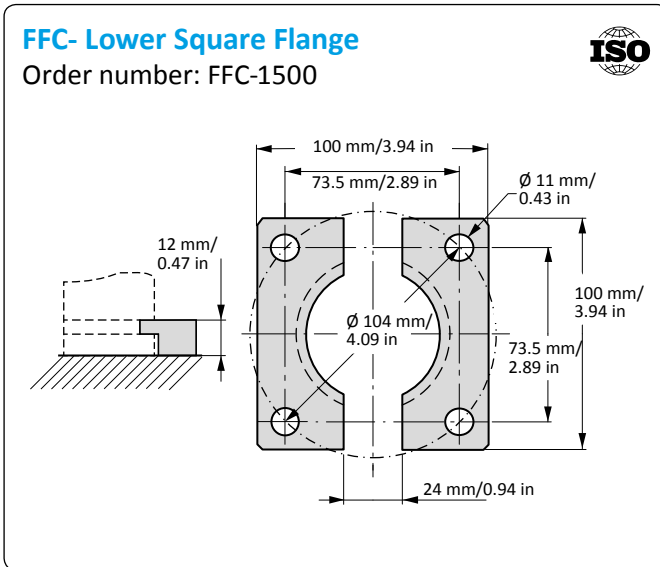
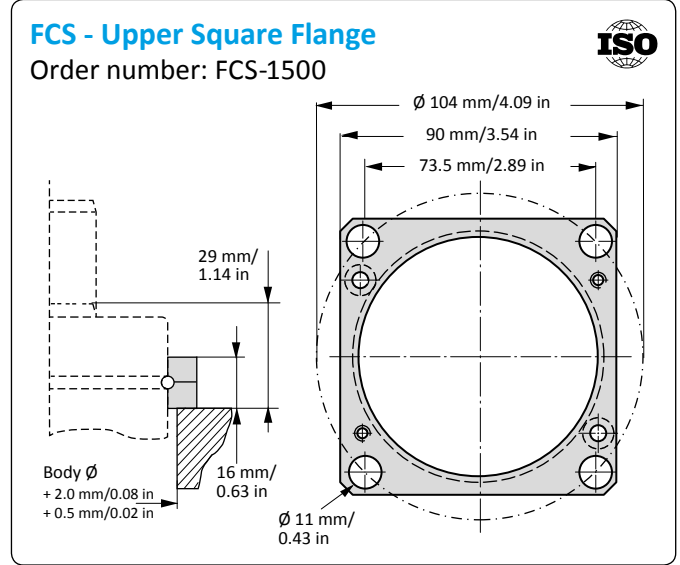
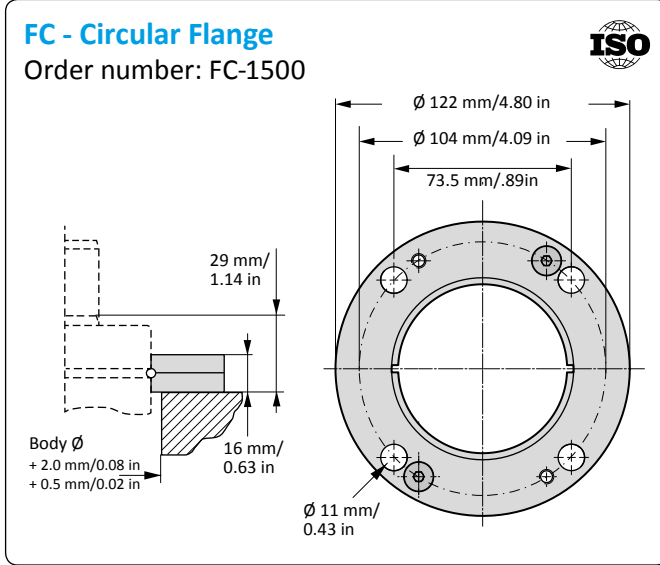

T3-4200

High Force Gas Springs



Advanced Safety Features



V>max
Overload Protection



P>max
Overpressure Protection

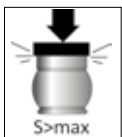

S>max
Overstroke Protection

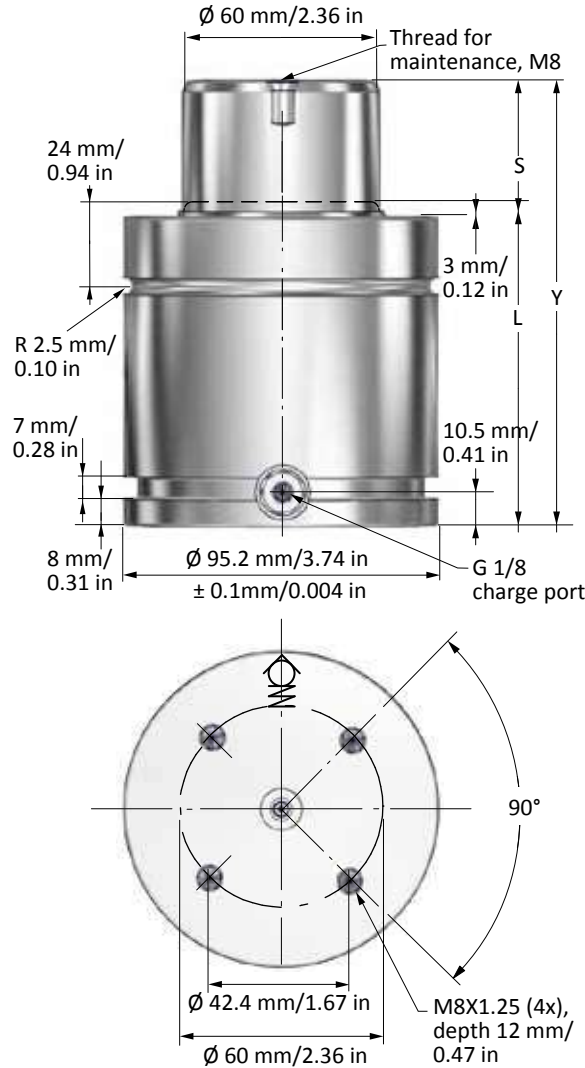

T3-4200 Dimensional Information

Order Number Model x Stroke	Stroke S		Contact Force 2175 psi at 68° F		Full Stroke Force		Cylinder Height		Body Height		Gas volume ℓ	Weight kg
	mm	in	N	lbf.	N	lbf.	Y ±0.25 mm	Y ±0.010 in	L mm	L in		
Preferred Stroke Lengths (optimal delivery)												
T3-4200x50	50	1.97	42,000	9,440	67,000	15,065	158	6.22	108	4.25	0.40	3.57
T3-4200x63	63	2.48			67,800	15,245	184	7.24	121	4.76	0.49	4.10
T3-4200x80	80	3.15			68,600	15,425	218	8.58	138	5.43	0.61	4.32
T3-4200x100	100	3.94			69,100	15,535	258	10.16	158	6.22	0.74	4.81
Alternative Stroke Lengths												
T3-4200x16	16	0.63	42,000	9,440	61,700	13,870	90	3.54	74	2.91	0.15	2.81
T3-4200x19	19	0.75			63,700	14,320	96	3.78	77	3.03	0.18	2.88
T3-4200x25	25	0.98			60,800	13,670	108	4.25	83	3.27	0.26	2.96
T3-4200x32	32	1.26			64,300	14,555	122	4.80	90	3.54	0.30	3.13
T3-4200x38	38	1.50			65,800	14,795	134	5.28	96	3.78	0.32	3.28
T3-4200x75	75	2.95			68,000	15,290	208	8.19	133	5.24	0.58	4.20
T3-4200x125	125	4.92			69,600	15,645	308	12.11	183	7.20	0.91	5.42

Note: All dimensions are nominal. Data shown are typical. Actual data for any particular unit may vary.

Note: All flanges ordered separately

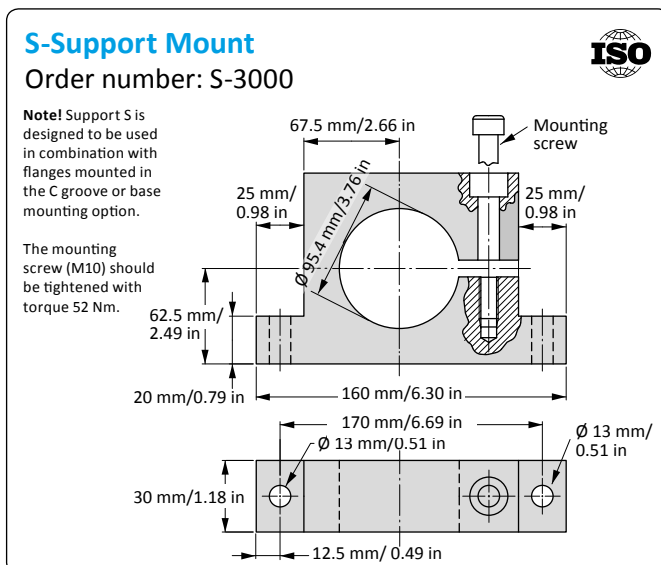
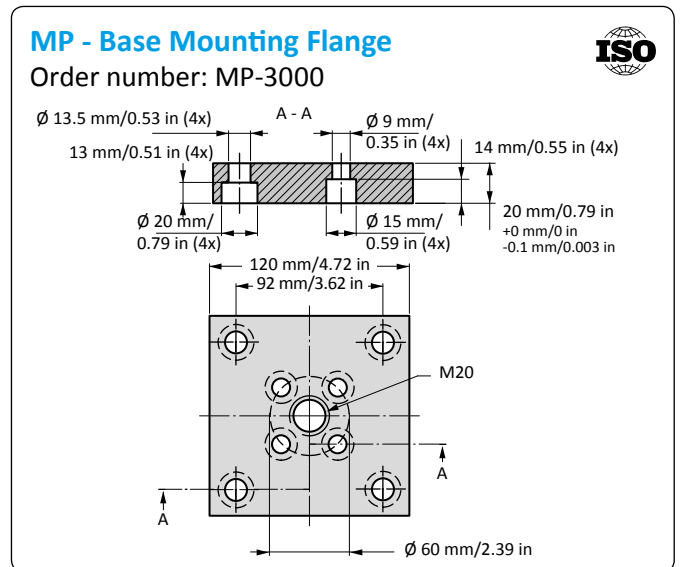
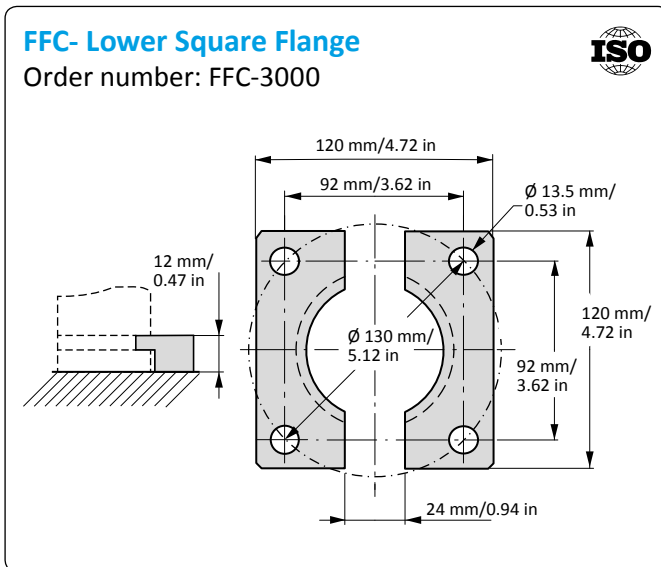
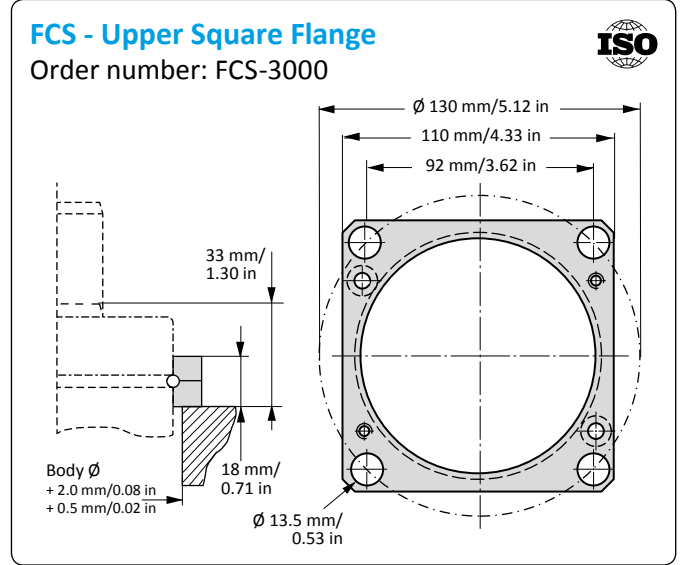
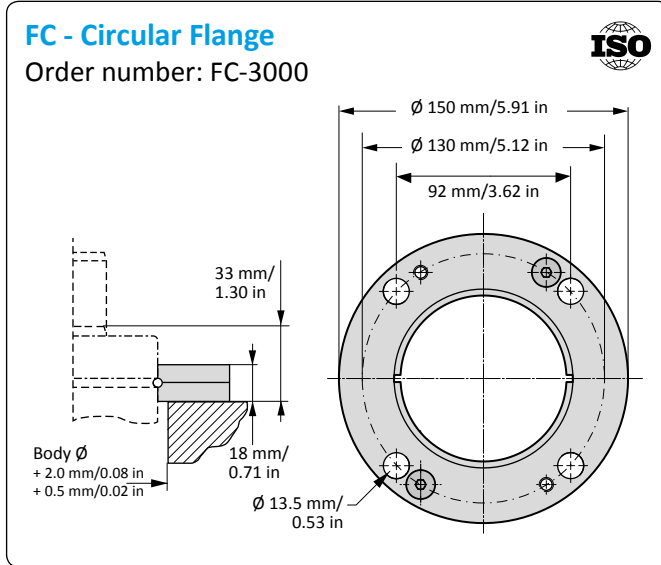

T3-6600

High Force Gas Springs

Advanced Safety Features



V>max
Overload Protection



P>max
Overpressure Protection

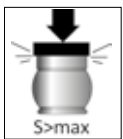

S>max
Overstroke Protection

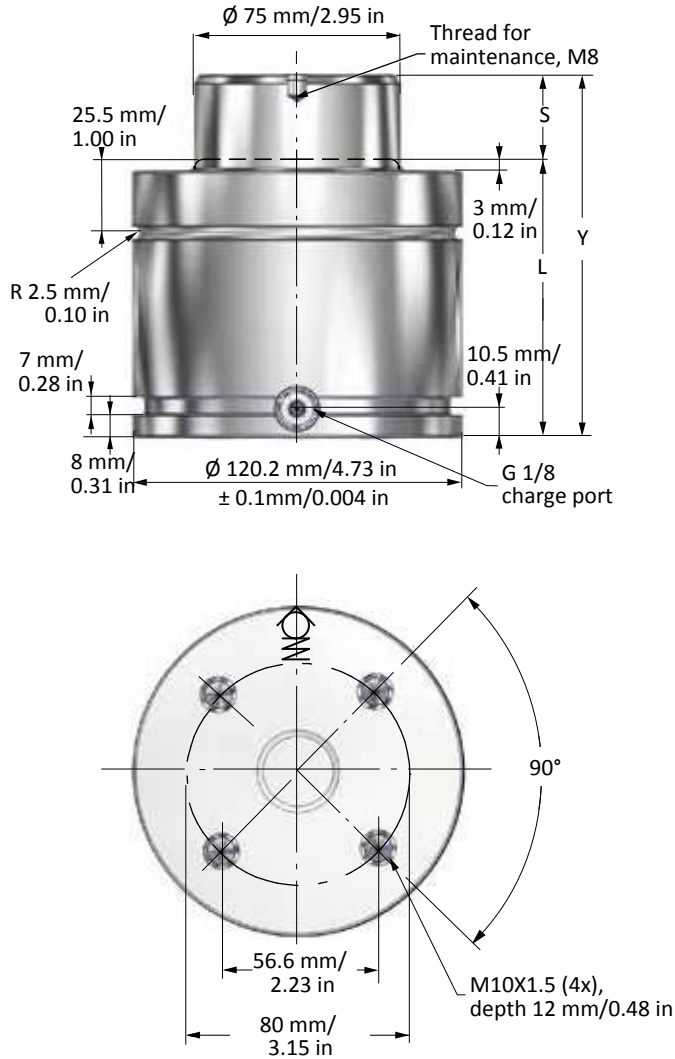

T3-6600 Dimensional Information

Order Number Model x Stroke	Stroke S		Contact Force 2175 psi at 68° F		Full Stroke Force		Cylinder Height		Body Height		Gas volume ℓ	Weight kg
	mm	in	N	lbf.	N	lbf.	Y ±0.25 mm	Y ±0.010 in	L mm	L in		
Preferred Stroke Lengths (optimal delivery)												
T3-6600x50	50	1.97	66,300	14,905	100,600	22,615	168	6.61	118	4.65	0.69	6.31
T3-6600x63	63	2.48			102,400	23,020	194	7.64	131	5.16	0.83	6.81
T3-6600x80	80	3.15			104,100	23,405	228	8.98	148	5.83	1.01	7.46
T3-6600x100	100	3.94			105,400	23,695	268	10.55	168	6.61	1.23	8.23
Alternative Stroke Lengths												
T3-6600x16	16	0.63	66,300	14,905	89,000	20,010	100	3.94	84	3.31	0.32	5.00
T3-6600x19	19	0.75			91,000	20,460	106	4.17	87	3.43	0.35	5.11
T3-6600x25	25	0.98			93,900	21,110	118	4.65	93	3.66	0.42	5.34
T3-6600x32	32	1.26			96,100	21,605	132	5.20	100	3.94	0.49	5.61
T3-6600x38	38	1.50			98,200	22,075	144	5.67	106	4.17	0.56	5.84
T3-6600x75	75	2.95			103,400	23,245	218	8.58	143	5.63	0.90	7.27
T3-6600x125	125	4.92			106,500	23,945	318	12.52	193	7.60	1.50	9.19

Note: All dimensions are nominal. Data shown are typical. Actual data for any particular unit may vary.

Note: All flanges ordered separately

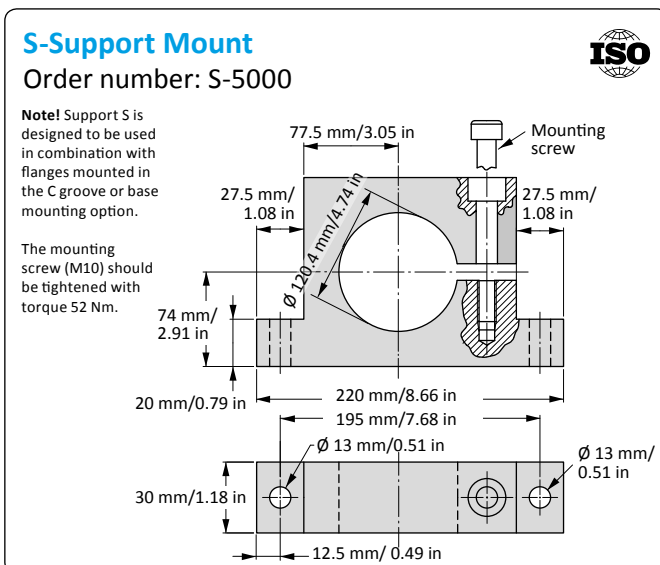
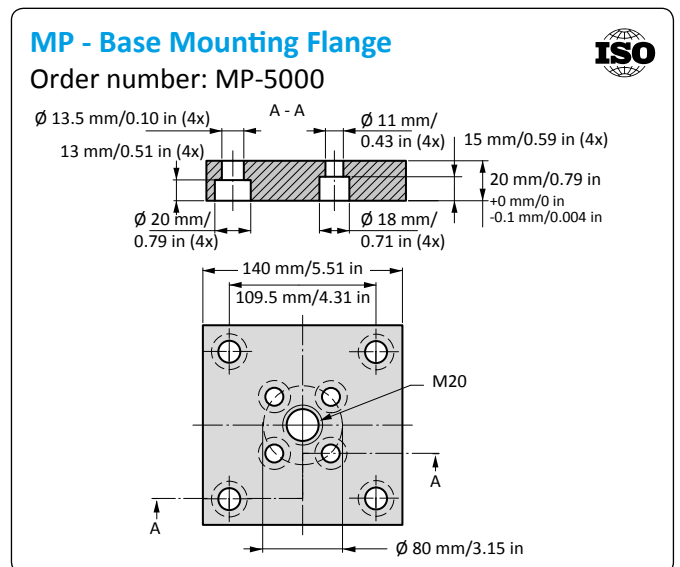
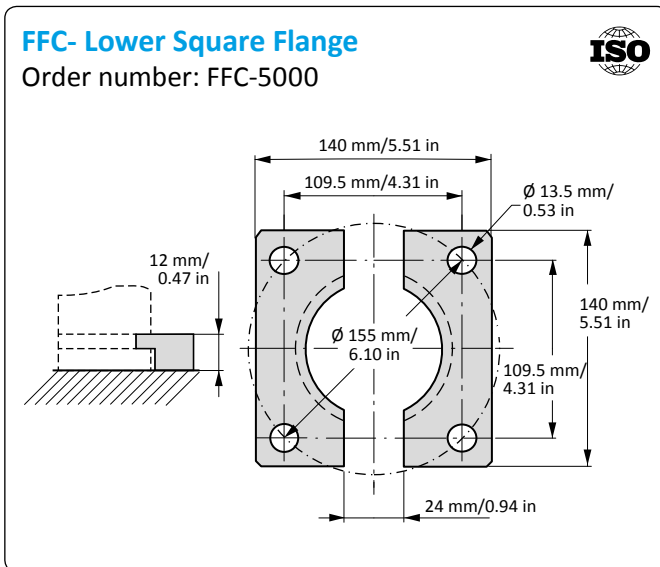
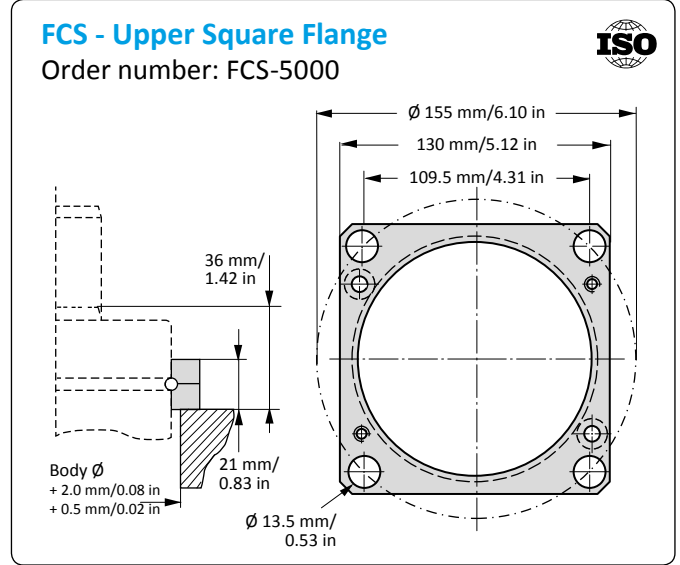
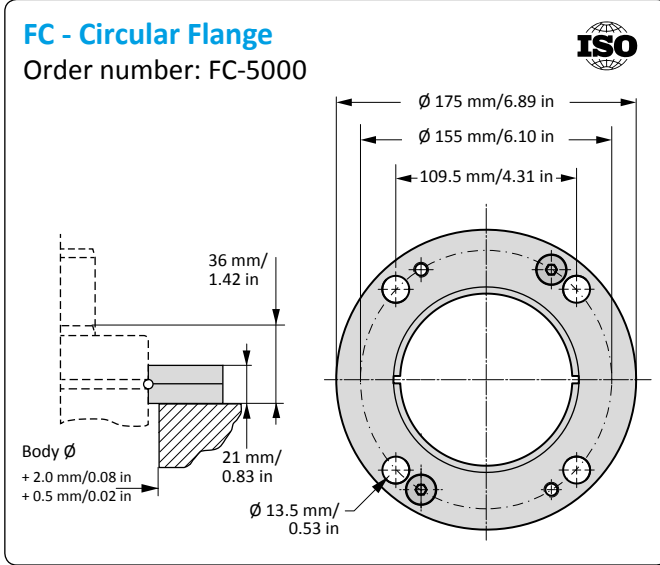

T3-9500

High Force Gas Springs

Advanced Safety Features



Overload Protection



Overpressure Protection

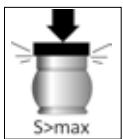

Overstroke Protection

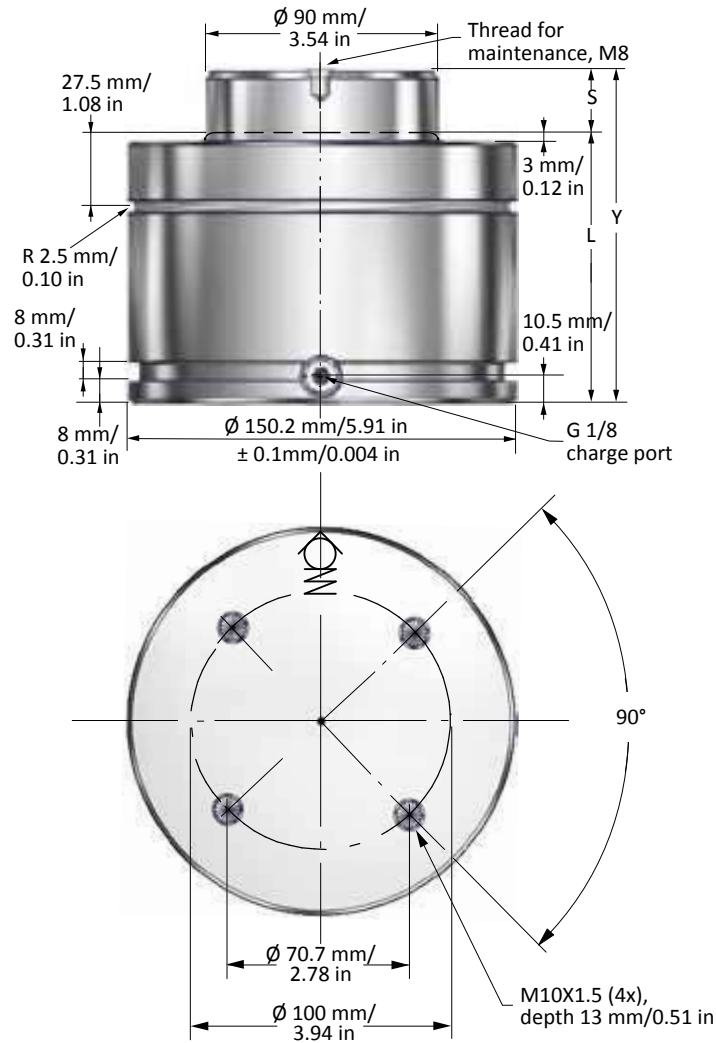

T3-9500 Dimensional Information

Order Number Model x Stroke	Stroke S		Contact Force 2175 psi at 68° F		Full Stroke Force		Cylinder Height		Body Height		Gas volume ℓ	Weight kg
	mm	in	N	lbf.	N	lbf.	Y ±0.25 mm	Y ±0.010 in	L mm	L in		
Preferred Stroke Lengths (optimal delivery)												
T3-9500x50	50	1.97	95,000	21,360	146,000	32,825	178	7.01	128	5.04	0.99	11.79
T3-9500x63	63	2.48			148,000	33,275	204	8.03	141	5.55	1.20	12.60
T3-9500x80	80	3.15			150,000	33,725	238	9.37	158	6.22	1.47	13.66
T3-9500x100	100	3.94			151,000	33,950	278	10.94	178	7.01	1.79	14.91
Alternative Stroke Lengths												
T3-9500x19	19	0.75	95,000	21,360	135,000	30,350	116	4.57	97	3.82	0.49	9.86
T3-9500x25	25	0.98			139,000	31,250	128	5.04	103	4.06	0.58	10.23
T3-9500x32	32	1.26			142,000	31,925	142	5.59	110	4.33	0.70	10.67
T3-9500x38	38	1.50			143,000	32,150	154	6.06	116	4.57	0.80	11.04
T3-9500x75	75	2.95			149,000	33,500	228	8.98	153	6.02	1.39	13.35
T3-9500x125	125	4.92			152,000	34,175	328	12.91	203	7.99	2.20	16.47

Note: All dimensions are nominal. Data shown are typical. Actual data for any particular unit may vary.

Note: All flanges ordered separately

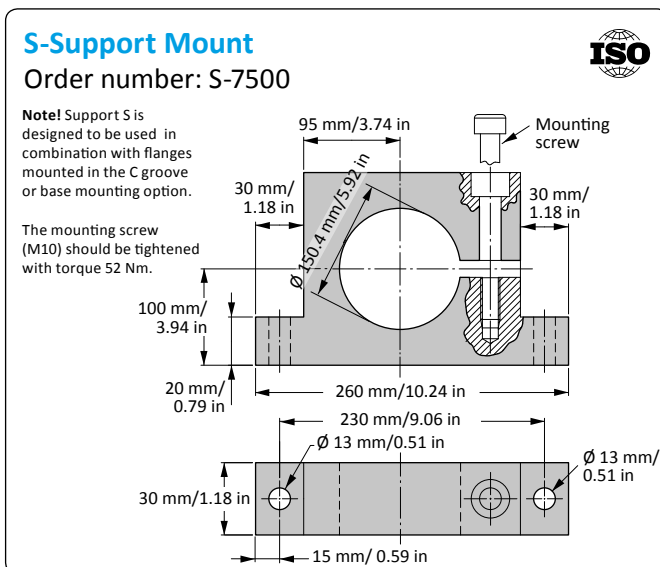
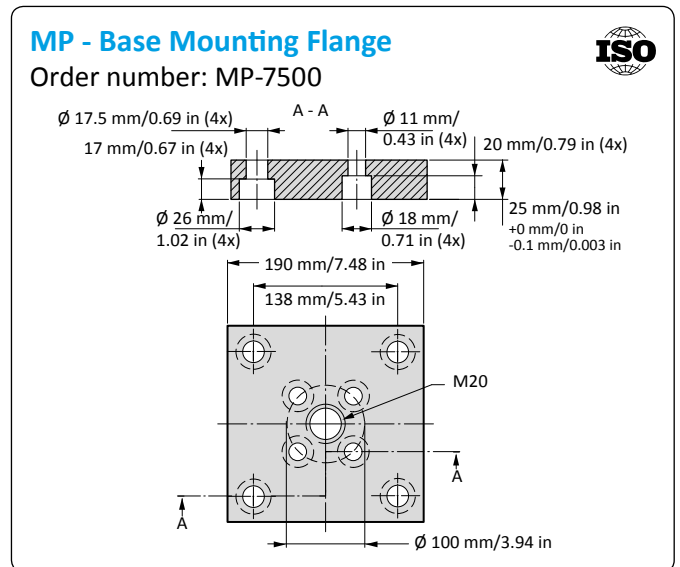
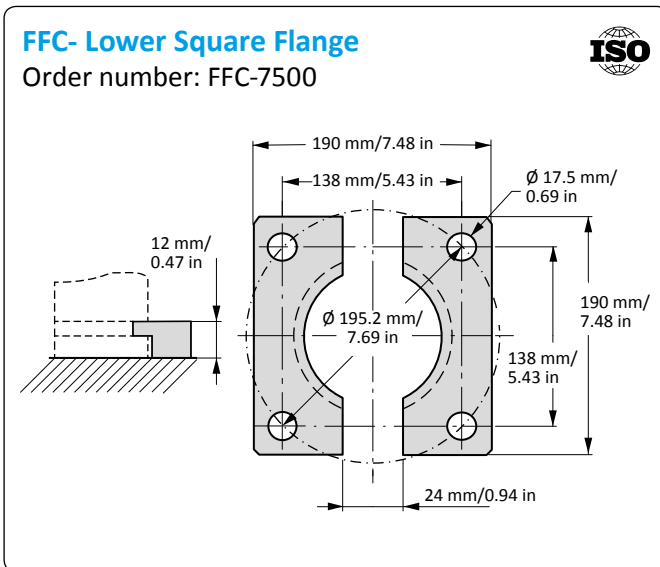
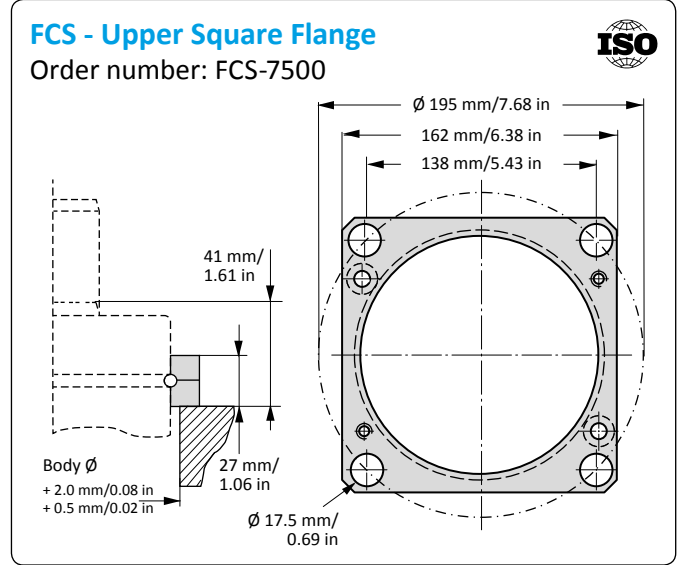
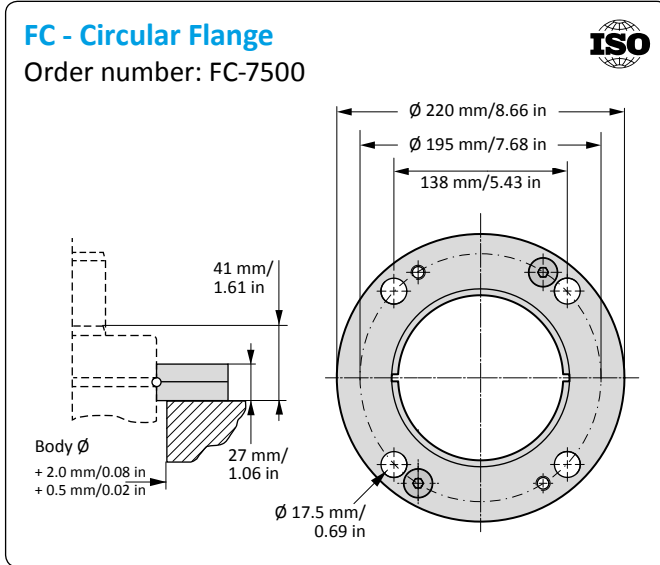

T3-20000

High Force Gas Springs

Advanced Safety Features



Overload Protection



Overpressure Protection

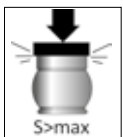

Overstroke Protection

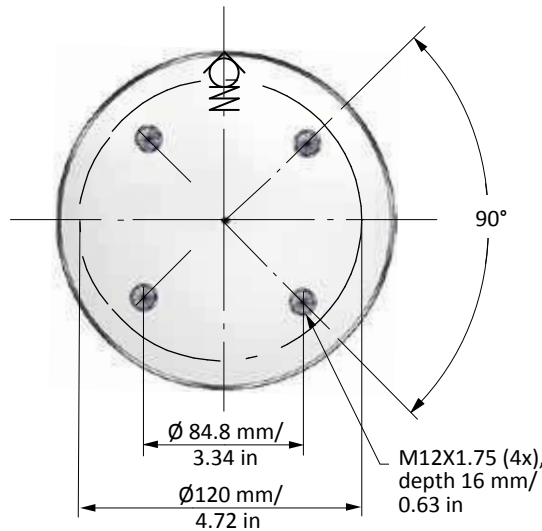
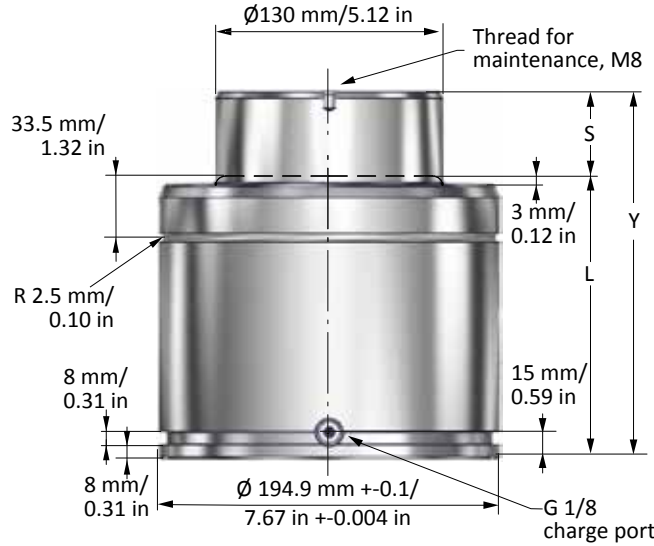

T3-20000 Dimensional Information

Order Number Model x Stroke	Stroke S		Contact Force 2175 psi at 68° F		Full Stroke Force		Cylinder Height		Body Height		Gas volume ℓ	Weight kg
	mm	in	N	lbf.	N	lbf.	Y ±0.25 mm	Y ±0.010 in	L mm	L in		
Preferred Stroke Lengths (optimal delivery)												
T3-20000x50	50	1.97	200,000	45,000	298,000	67,000	210	8.27	160	6.30	2.12	24.87
T3-20000x63	63	2.48			307,000	69,100	236	9.29	173	6.81	2.50	26.28
T3-20000x80	80	3.15			315,000	70,900	270	10.63	190	7.48	3.00	28.13
T3-20000x100	100	3.94			323,000	72,700	310	12.20	210	8.27	3.58	30.30
Alternative Stroke Lengths												
T3-20000x19	19	0.75	200,000	45,000	259,000	58,200	148	5.83	129	5.08	1.21	21.50
T3-20000x25	25	0.98			270,000	60,750	160	6.30	135	5.31	1.38	22.16
T3-20000x32	32	1.26			280,000	63,000	174	6.85	142	5.59	1.59	22.92
T3-20000x38	38	1.50			287,000	64,600	186	7.32	148	5.83	1.77	23.57
T3-20000x75	75	2.95			313,000	70,500	260	10.24	185	7.28	2.85	27.59
T3-20000x125	125	4.92			330,000	74,250	360	14.17	235	9.25	4.31	33.02

Note: All dimensions are nominal. Data shown are typical. Actual data for any particular unit may vary.

Note: All flanges ordered separately

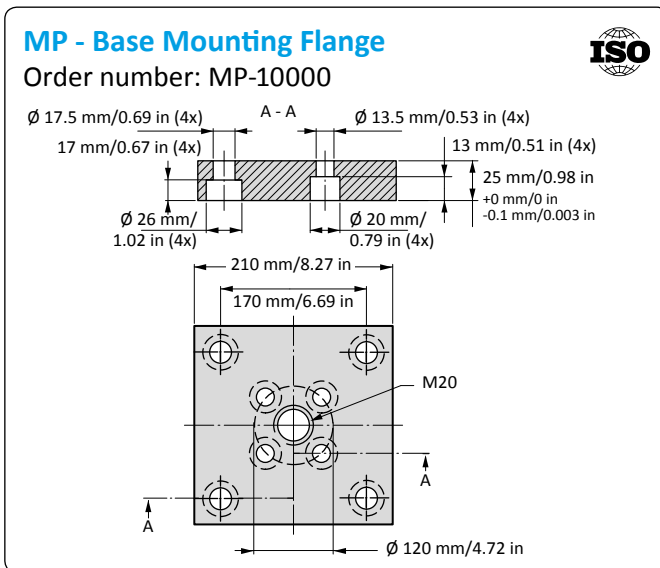
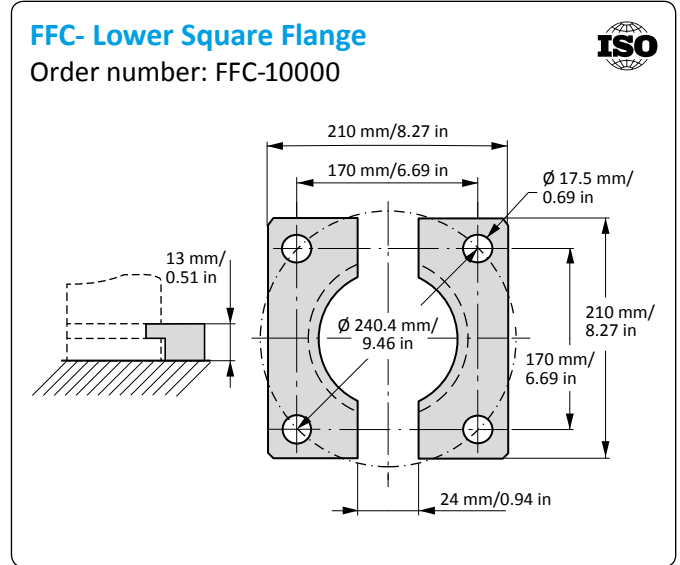
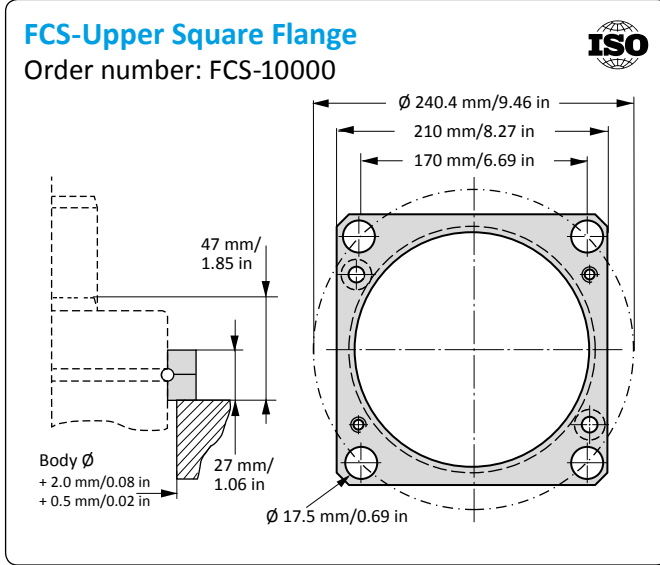

HYSON

Metal Forming Solutions™

Sales partner in Mexico:



ACAT MEXICANA

Ave. Regio Parque #200 Regio Parque Industrial
Apodaca, Nuevo León, México CP. 66633



acat@acatmexicana.com



TEL. 81 8354 8910



www.acatmexicana.com